



TYPICAL

GC6730 SERIES

SINGLE NEEDLE DIRECT DRIVE LOCK
STITCHER WITH THREAD TRIMMER
INSTRUCTION BOOK
PARTS CATALOGUE

XI'AN TYPICAL INDUSTRIES CO.,LTD.

Thank you very much for buying our company's sewing machine. Before using your new machine, please read the safety instructions below and the explanations given in the instruction manual.

With industrial sewing machines, it is normal to carry out work while positioned directly in front of moving parts such as the needle and thread take-up lever, and consequently there is always a danger of injury that can be caused by these parts. Follow the instructions from training personnel and instructors regarding safe and correct operation before operating the machine so that you will know how to use it correctly.

SAFETY INSTRUCTIONS

1. Safety indications and their meanings

This instruction manual and the indications and symbols that are used on the machine itself are provided in order to ensure safe operation of this machine and to prevent accidents and injury to yourself or other people.

The meanings of these indications and symbols are given below.

Indications



CAUTION

The instructions which follow this term indicate situations where failure to follow the instructions could cause injury when using the machine or physical damage to equipment and surroundings.

Symbols



..... This symbol (△) indicates something that you should be careful of. The picture inside the triangle indicates the nature of the caution that must be taken.



..... (For example, ⊘ the symbol at left means "beware of injury".)



..... This symbol (⊘) indicates something that you must not do.
This symbol (●) indicates something that you must do. The picture inside the circle indicates the nature of the thing that must be done.
(For example, the symbol at left means "you must make the ground connection".)

2. Notes on safety

DANGER



Wait at least 5 minutes after turning off the power switch and disconnecting the power cord from the wall outlet before opening the face plate of the control box. Touching areas where high voltages are present can result in severe injury.

CAUTION

Environmental requirements



Use the sewing machine in an area which is free from sources of strong electrical noise such as high – frequency welders. Sources of strong electrical noise may cause problems with correct operation.



Any fluctuations in the power supply voltage should be within $\pm 10\%$ of the rated voltage for the machine. Voltage fluctuations which are greater than this may cause problems with correct operation.



The power supply capacity should be greater than the requirements for the sewing machine's electrical consumption. Insufficient power supply capacity may cause problems with correct operation.



The ambient temperature should be within the range of 5°C to 35°C during use. Temperatures which are lower or higher than this may cause problems with correct operation.



The relative humidity should be within the range of 45% to 85% during use, and no dew formation should occur in any devices. Excessively dry or humid environments and dew formation may cause problems with correct operation.



Avoid exposure to direct sunlight during use. Exposure to direct sunlight may cause problems with correct operation.



In the event of an electrical storm, turn off the power and disconnect the power cord from the wall outlet. Lightning may cause problems with correct operation.

Installation



Machine installation should only be carried out by a qualified technician.



Contact your dealer or a qualified electrician for any electrical work that may need to be done.



The sewing machine weighs more than 44 kg. The installation should be carried out by two or more people.



Do not connect the power cord until installation is complete. The machine may operate if the treadle is depressed by mistake, which could result in injury.



Turn off the power switch before inserting or removing the plug, otherwise damage to the control box could result.



Be sure to connect the ground. If the ground connection is not secure, you run a high risk of receiving a serious electric shock, and problems with correct operation may also occur.



When securing the cords, do not bend the cords excessively or fasten them too hard with staples, otherwise there is the danger that fire or electric shocks could occur.



If using a work table which has casters, the casters should be secured in such a way so that they cannot move.



Use both hands to hold the machine head when tilting it back or returning it to its original position. If only one hand is used, the weight of the machine head may cause your hand to slip, and your hand may get caught.



Be sure to wear protective goggles and gloves when handling the lubricating oil and grease, so that they do not get into your eyes or onto your skin, otherwise inflammation can result.

Furthermore, do not drink the oil or eat the grease under any circumstances, as they can cause vomiting and diarrhea.

Keep the oil out of the reach of children.



CAUTION

Sewing



This sewing machine should only be used by operators who have received the necessary training in safe use beforehand.



The sewing machine should not be used for any applications other than sewing.



Be sure to wear protective goggles when using the machine.

If goggles are not worn, there is the danger that if a needle breaks, parts of the broken needle may enter your eyes and injury may result.



Turn off the power switch at the following times.

The machine may operate if the treadle is depressed by mistake, which could result in injury.

- When threading the needle
- When replacing the bobbin and needle
- When not using the machine and when leaving the machine unattended.



If using a work table which has casters, the casters should be secured in such a way so that they cannot move.



Attach all safety device before using the sewing machine.

If the machine is used without these devices attached, injury may result.



Do not touch any of the moving parts or press any objects against the machine while sewing, as this may result in personal injury or damage to the machine.



Use both hands to hold the machine head when tilting it back or returning it to its original position. If only one hand is used, the weight of the machine head may cause your hand to slip, and your hand may get caught.



If an error occurs in machine, or if abnormal noises or smells are noticed, immediately turn off the power switch. Then contact your nearest dealer or a qualified technician.



If the machine develops a problem, contact your nearest dealer or a qualified technician.

Cleaning



Turn off the power switch before carrying out cleaning. The machine may operate if the treadle is depressed by mistake, which could result in injury.



Use both hands to hold the machine head when tilting it back or returning it to its original position. If only one hand is used, the weight of the machine head may cause your hand to slip, and your hand may get caught.



Be sure to wear protective goggles and gloves when handling the lubricating oil and grease, so that they do not get into your eyes or onto your skin, otherwise inflammation can result.

Furthermore, do not drink the oil or eat the grease under any circumstances, as they can cause vomiting and diarrhea.

Keep the oil out of the reach of children.

3.Warning labels.

The following warning labels appear on the sewing machine.

Please follow the instructions on the labels at all times when using the machine. If the labels have been removed or are difficult to read, please contact your nearest dealer.

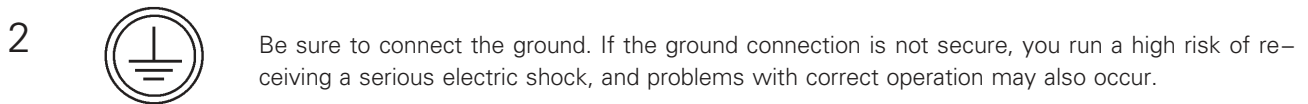

safety devices:
 (A) Finger guard
 (B) Thread take-up cover

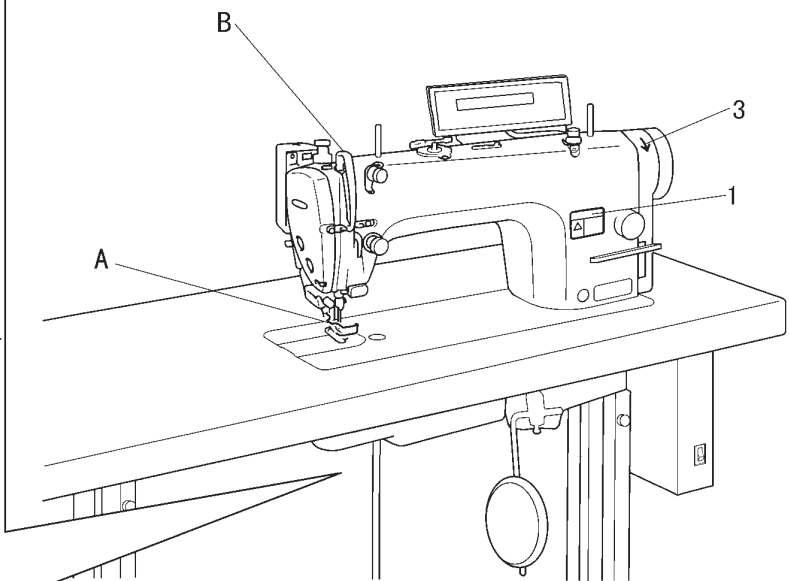
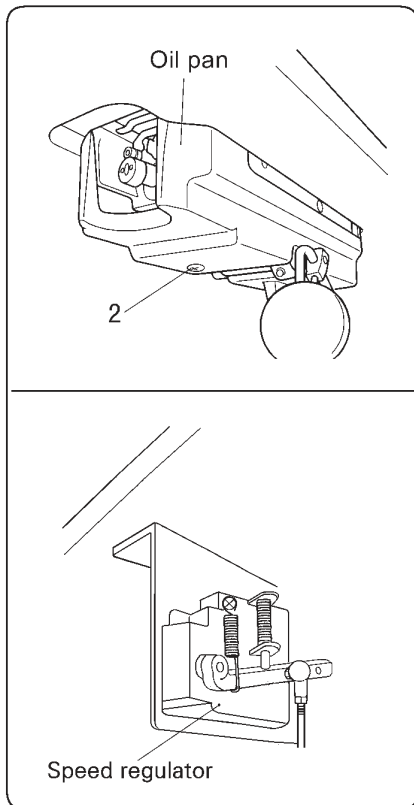

1. NAMES OF MAJOR PARTS

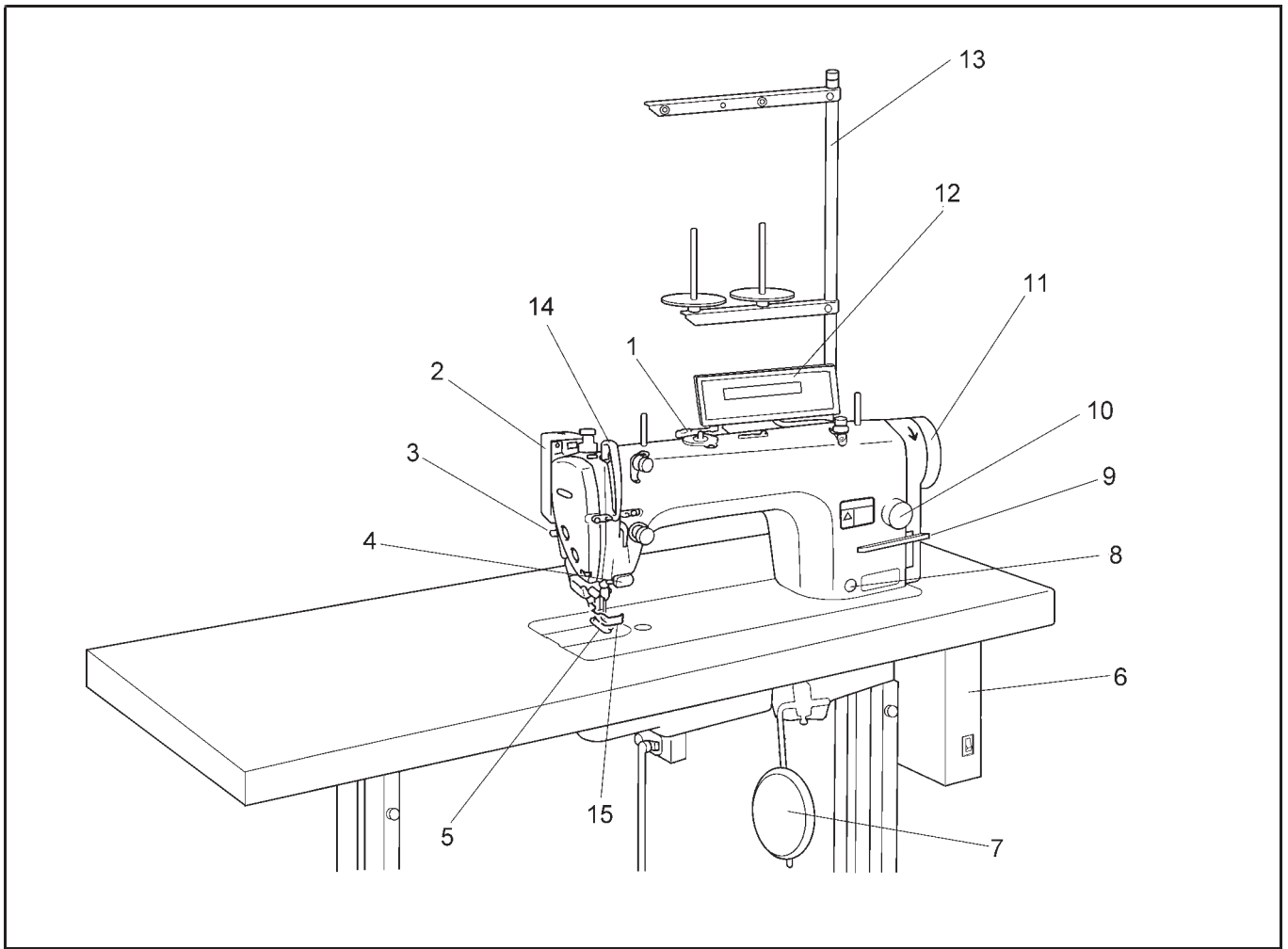

1. Bobbin winder

3. Lifting lever

5. Presser foot

7. Knee lifter assembly

9. Reverse lever

11. Machine pulley

13. Cotton stand

2. Thread wiper

4. Quick reverse(Actuator)

6. Control box

8. Oil gauge window

10. Stitch length dial

12. Operation panel

Safety devices

14. Thread take-up cover

15. Finger guard

2.INSTALLATION

CAUTION

 Machine installation should only be carried out by a qualified technician.

 Contact your dealer or a qualified electrician for any electrical work that may need to be done.

 The sewing machine weighs more than 44kg. The installation should be carried out by two or more people.

 Do not connect the power cord until installation is complete. The machine may operate if the treadle is depressed by mistake, which could result in injury.

 Use both hands to hold the machine head when tilting it back or returning it to its original position. If only one hand is used, the weight of the machine head may cause your hand to slip, and your hand may get caught.

About the machine set-up location

- Do not set up this sewing machine near other equipment such as televisions, radios or cordless telephones, otherwise such equipment may be affected by electronic interference from the sewing machine.
- The sewing machine should be plugged directly into an AC wall outlet. Operation problems may result if extension cords are used.

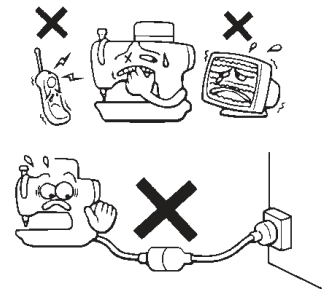

Carrying the machine

- The machine should be carried by the arm by two people as shown in the illustration.
- * Hold the motor cover (A) by hand also so that the pulley does not rotate.

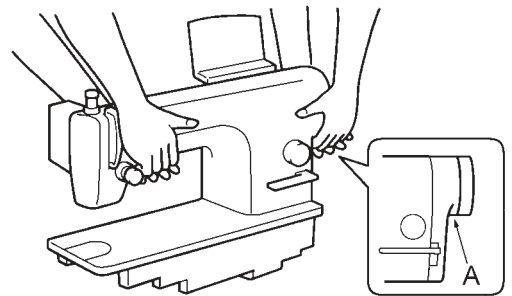

Tilting back the machine head

- Hold section (B) with your foot so that the table does not move, and then push the arm with both hands to tilt back the machine head.

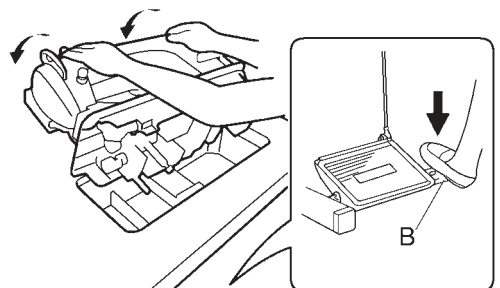

Returning the machine head to the upright position

1. clear away any tools, etc. which may be near the table holes.
2. While holding the face plate with your left hand, gently return the machine head to the upright position with your right hand.

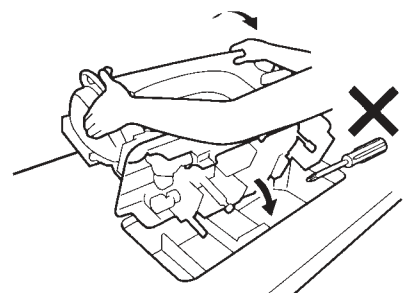

2-1. Table processing diagram

The top of the table should be 40 mm in thickness and should be strong enough to hold the weight and with-stand the vibration of the sewing machine.

Drill holes as indicated in the illustration below.

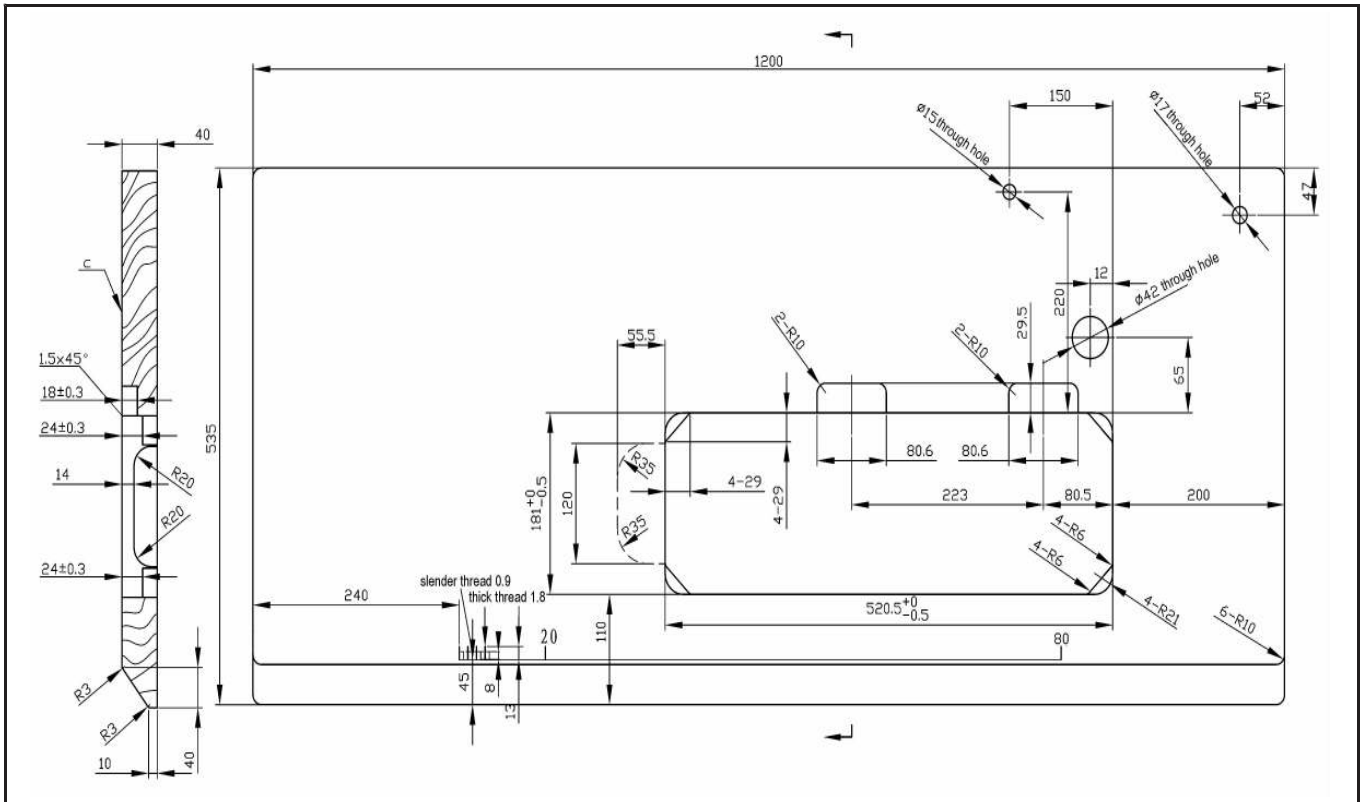

2-2. Installation

1. Control box
- (1) control box
- (2) Screws [4 pcs]

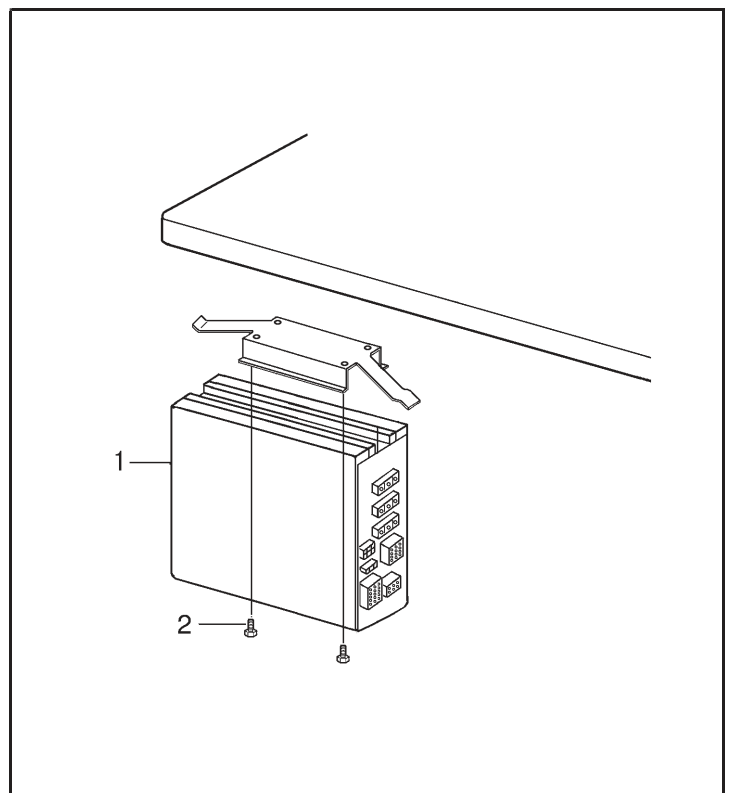

2.Oil pan

(1) Head cushions (left) [2 pcs]

(2)Head cushions (right) [2 pcs]

(3) Oil pan.

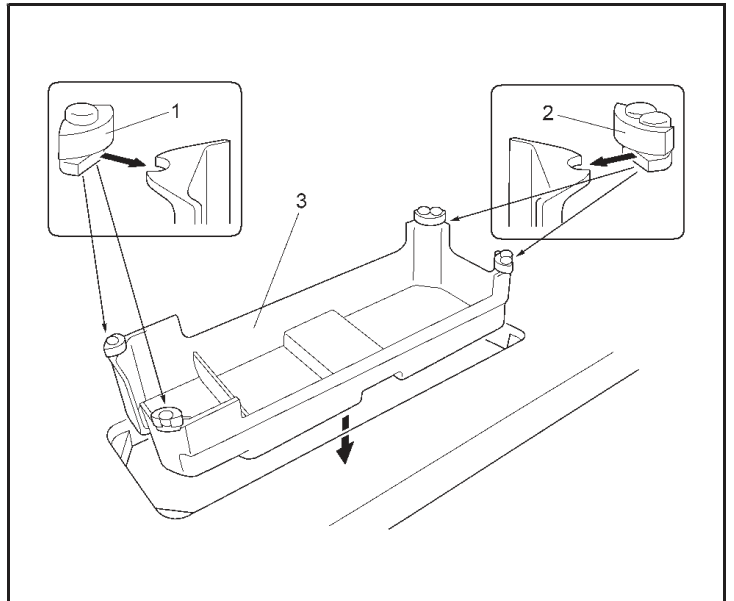

3.Rubber cushions

(1)Rubber cushions[2 pcs]

4.Knee lifter complying bar

(2) Knee lifter complying bar

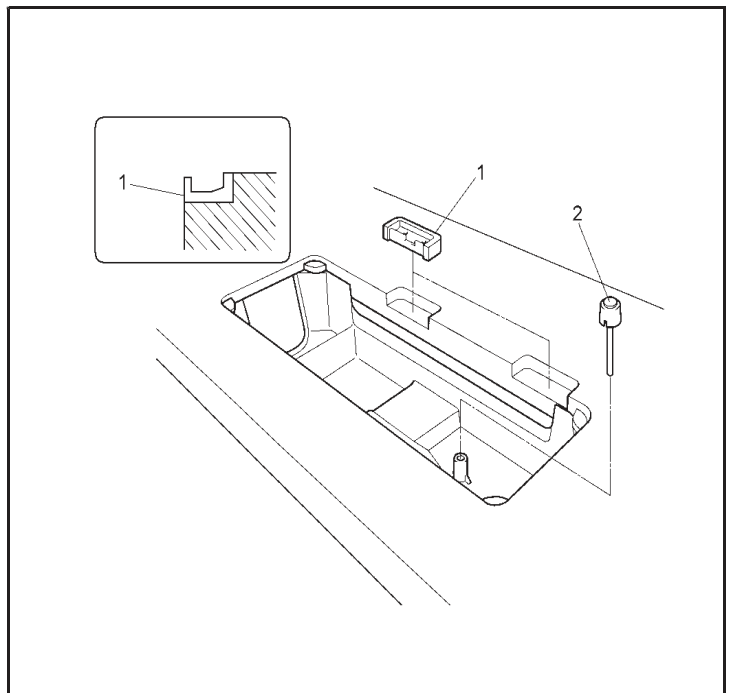

5.Machine head

(1) Hinges [2 pcs]

(2) Machine head

(3) Head rest

NOTE:

Tap the head rest (3) securely into the table hole. If the head rest (3) is not pushed in as far as it will go, the machine head will not be sufficiently stable when it is tilted back.

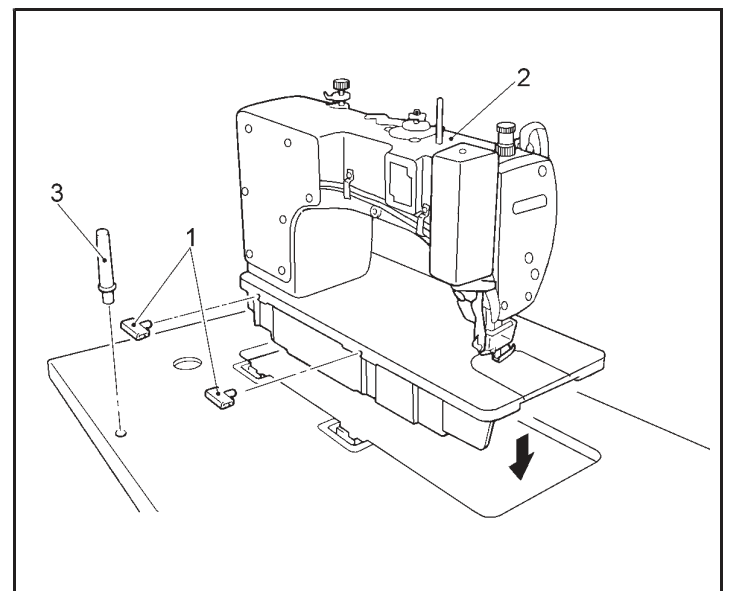

6. Operation panel
 (1) Operation panel
 (2) Screws [2 pcs]
 (Use for tightening rear cover)

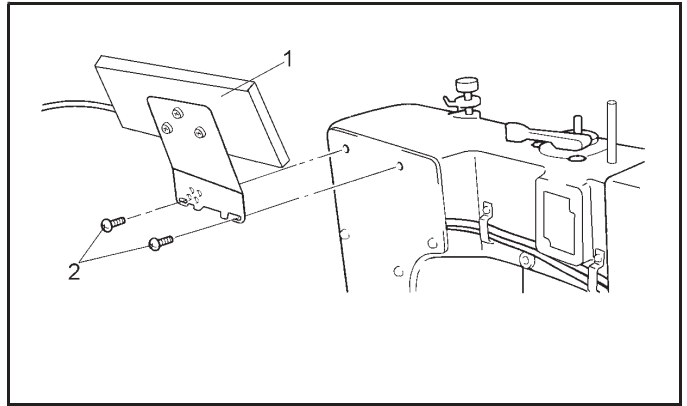

7. Sticker (Remove)
 (1) sticker

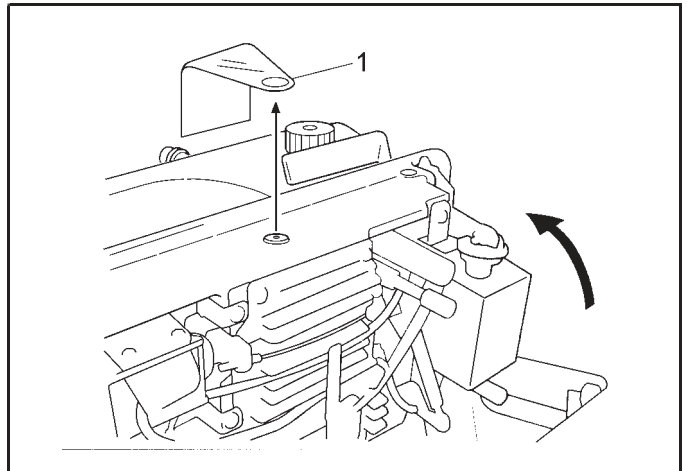

8. Cotton stand
 (1) cotton stand
 NOTE:
 Securely tighten the nut (4) so that the rubber gasket (2) and the washer (3) are securely clamped and so that the cotton stand (1) does not move.

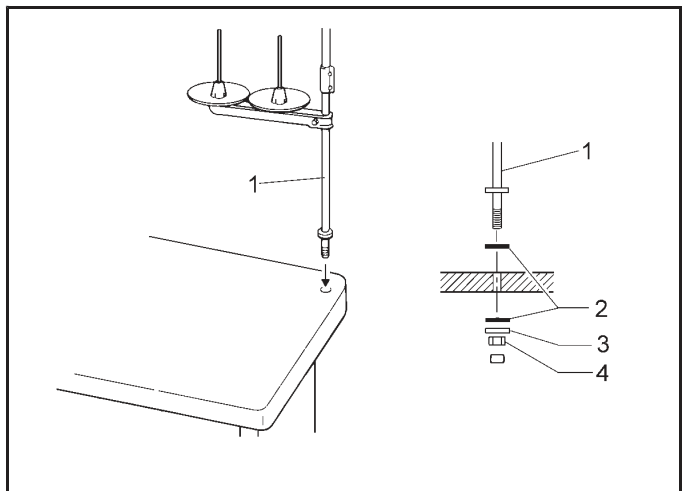

9. Knee lifter plate
 (1) Knee lifter plate
 (2) Bolt
 * Loosen the bolt (3) and move the knee lifter plate (1) to a position where it is easy to use.

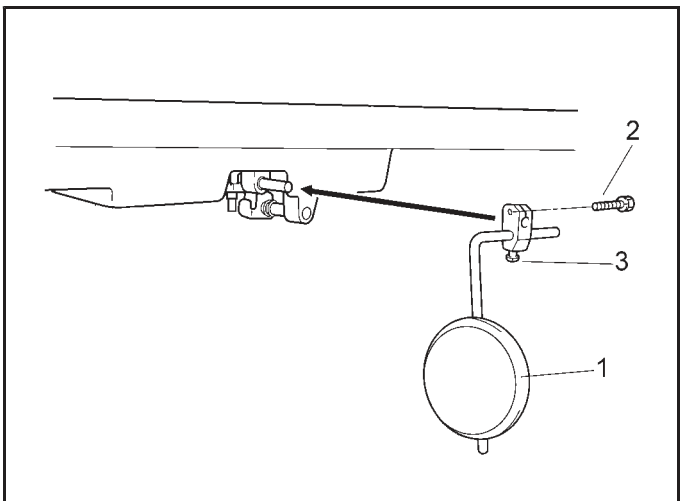

<Knee lifter adjustment>

1. Turn the machine pulley so that the feed dog is below the top of the needle plate.
2. Lower the presser foot (5) by using the lifting lever(4).

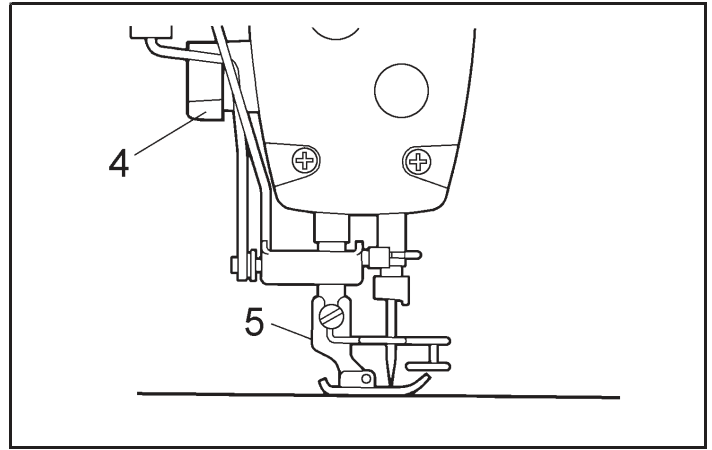

3. Loosen the nut(6).
4. Turn the screw (8) to adjust so that the amount of play in the knee lifter (7) is approximately 2 mm when the knee lifter plate (1) is gently pressed.
5. Securely tighten the nut (6)
6. loosen the nut (9)
7. Turn the screw (10) until the distance between the end of the screw (10) and the knee lifter (11) is approximately 8 mm.
8. Turn the adjusting screw (10) to adjust so that the presser foot (5) is at the desired position within a distance of 13 mm of the needle plate when the knee lifter plate (1) is fully pressed.
9. After adjustment is completed, securely tighten the nut (9).

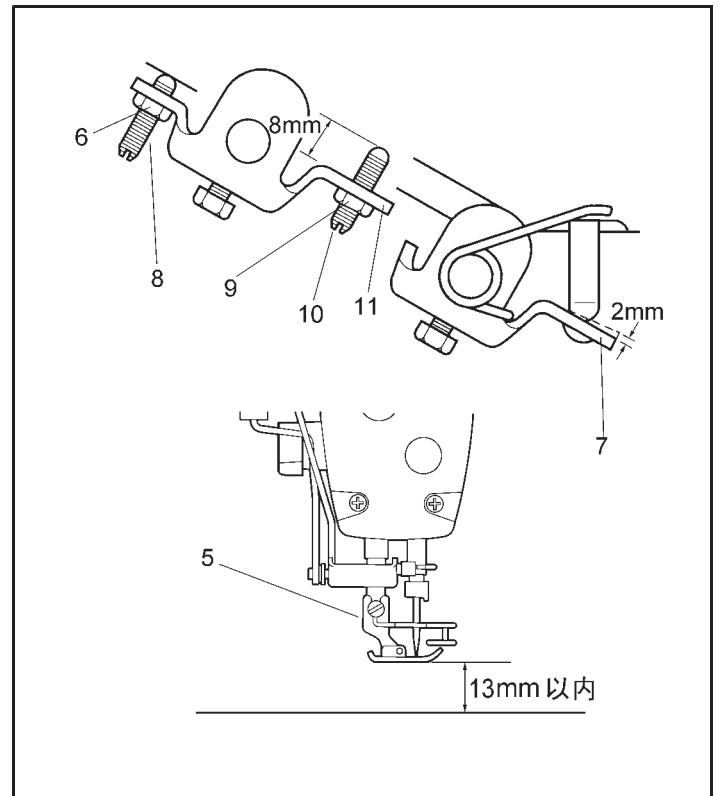

2-3. Lubrication



CAUTION



Do not connect the power cord until lubrication has been completed, otherwise the machine may operate if the treadle is depressed by mistake, which could result in injury.



Be sure to wear protective goggles and gloves when handling the lubricating oil and grease, so that they do not get into your eyes or onto your skin, otherwise inflammation can result.

Furthermore, do not drink the oil or eat the grease under any circumstances, as they can cause vomiting and diarrhea.

Keep the oil out of the reach of children.

● The sewing machine should always be lubricated and the oil supply replenished before it is used for the first time, and also after long periods of non-use.

● Use only the lubricating oil our company.

1. Remove the rubber cap (1), and pour 130 ml of lubricating oil from the accessory oil bottle (2) into the oil tank (3)
(Use the reference line (4) as a guide when pouring)

2. Replace the rubber cap (1)

3. Check that the oil gauge (4) comes to the upper reference line in the oil gauge window (3)

* Be sure to add more oil if the oil gauge (4) is below the lower reference line.

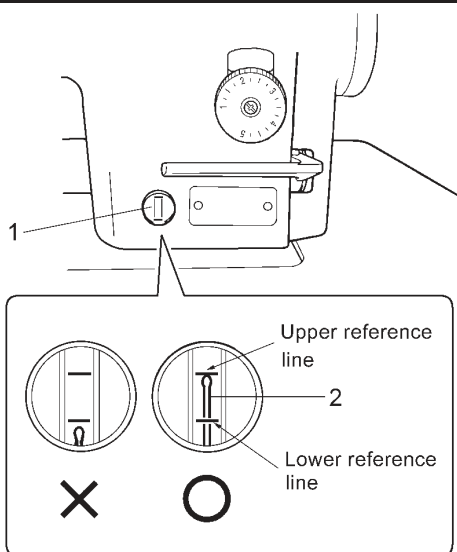

2-4 Test operation (Operating the treadle)



CAUTION



Do not touch any of the moving parts or press any objects against the machine while sewing, as this may result in personal injury or damage to the machine.

<Turning on the power>

Press the ON power switch (1)

The power indicator (2) will illuminate.

<Test operation >

1. Check that the machine sews at low speed when the treadle (3) is gently pressed to position (B).

2. Then check that it sews at high speed when the treadle (3) is gently pressed to position (C).

3. After pressing the treadle (3) forward, check that the needle is lowered to the needle plate when the treadle (3) is returned to the neutral position (A).
(when needle down stopping has been set.)

4. If the treadle (3) is pressed to position (D), thread trimming is carried out and the needle then rises above the needle plate and stops.

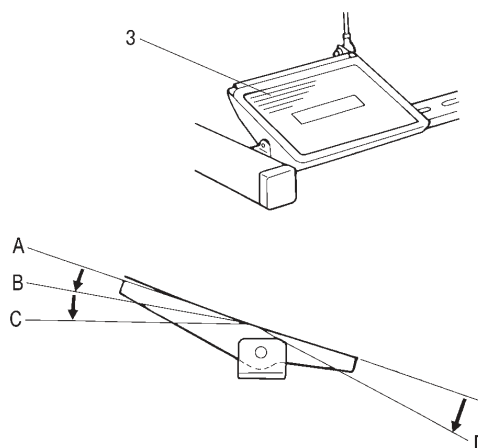

3. PREPARATION BEFORE SEWING

3-1.Installing the needle



CAUTION



Turn off the power switch before installing the needle.
The machine may operate if the treadle is depressed by mistake, which could result in injury .

1. turn the machine pulley to move the needle bar to its highest position.
2. Loosen the screw (1).
3. Insert the needle (2) in a straight line as far as it will go, making sure that the long groove on the needle is at the left, and then securely tighten the screw(1).

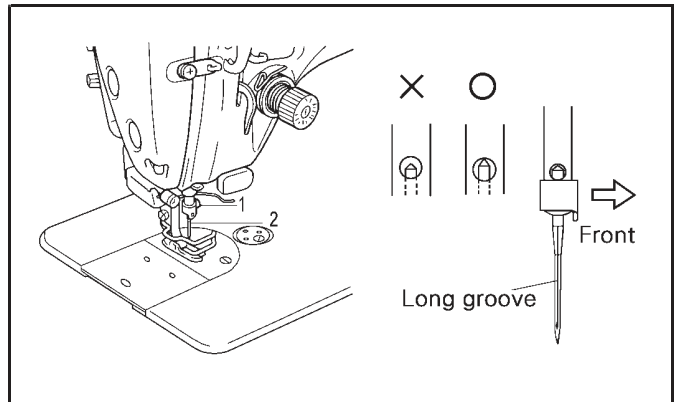

3-2.Removing the bobbin case



CAUTION



Turn off the power switch before removing the bobbin case.
The machine may operate if the treadle is depressed by mistake, which could result in injury .

1. Turn the machine pulley to raise the needle until it is above the needle plate.
 2. Pull the latch (1)of the bobbin case upward and then remove the bobbin case.
 3. The bobbin (2) will come out when the latch (1) is released .
- * There is an anti-spin spring(3) inside the bobbin case .
the anti-spin spring(3) prevents the bobbin from racing at times such as during thread trimming.

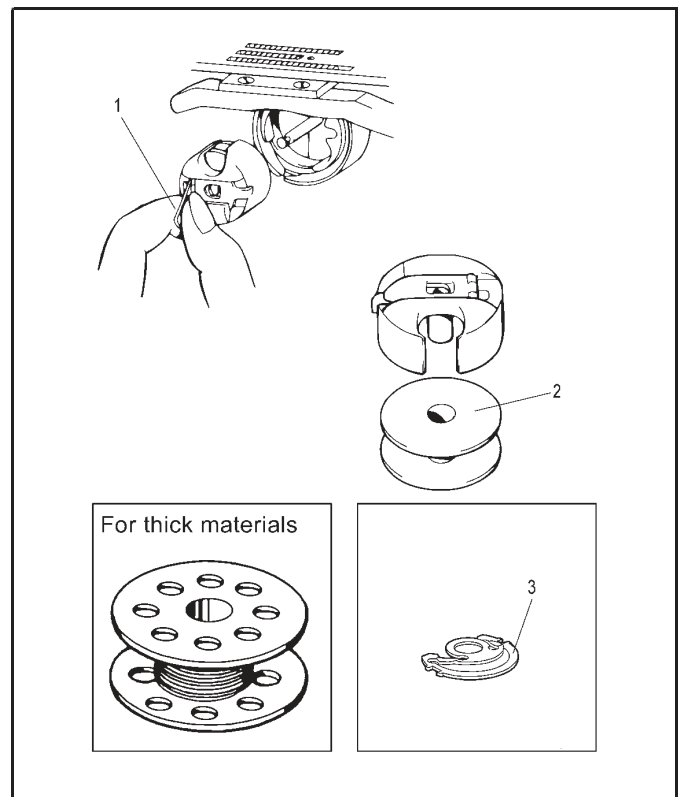

3-3. Winding the lower thread



Do not touch any of the moving parts or press any objects against the machine while the lower thread, as this may result in personal injury or damage to the machine.

1. Turn on the power switch.
 2. Place the bobbin (1) onto the bobbin winder shaft(2).
 3. Wind the thread several times around the bobbin(1) in the direction indicated by the arrow.
 4. Push the bobbin presser arm(3) toward the bobbin (1).
 5. Raise the presser foot with the lifting lever .
 6. Depress the treadle. Lower thread winding will then start.
 7. Once winding of the lower thread is completed, the bobbin presser arm (3) will return automatically.
 8. After the thread has been wound on ,remove the bobbin and cut the thread with the thread cutter(4).
- * Loosen the screw (5) and mover the thread cutter(4) to adjust the amount of thread wound onto the bobbin.

NOTE:

The amount of thread wound onto the bobbin should be a maximum of 80% of the bobbin capacity.

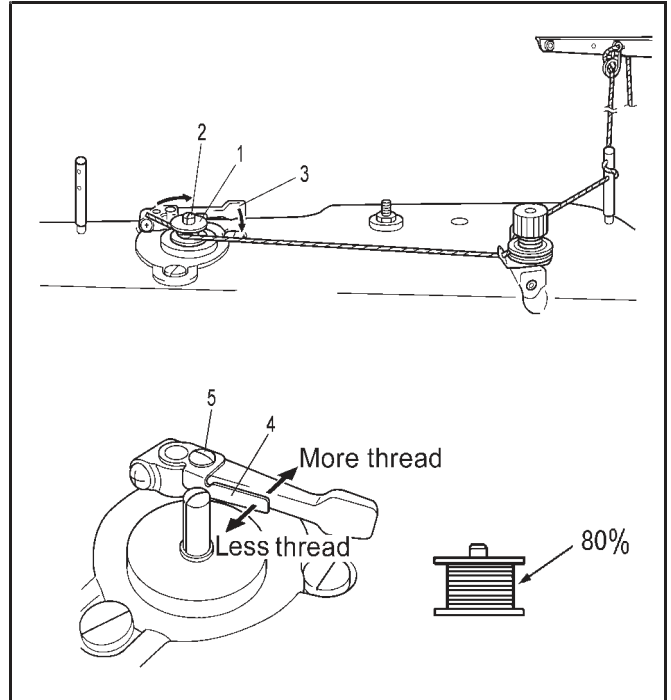

3-4 Installing the bobbin case



Turn off power switch before installing the bobbin case.
The machine may operate if the treadle is depressed by mistake , which could result in injury.

1. Turn the machine pulley to raise the needle until it is above the needle plate.
2. While holding the bobbin so that the thread winds to the right, insert the bobbin into the bobbin case.
3. Pass the thread through the slot (1) and under the tension spring (2), and then pull it out from the thread guide(3).
4. Check that bobbin turns clockwise when the thread is pulled.
5. Hold the latch (4) on the bobbin case and insert the bobbin case into the rotary hook..

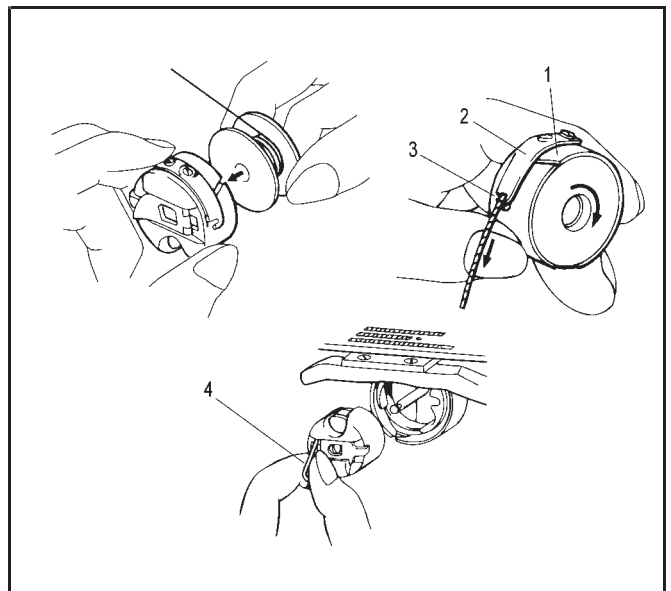

3-5 Threading the upper thread



CAUTION



Turn off the power switch before threading the upper thread.

The machine may operate if the treadle is depressed by mistake. Which could result in injury.

Turn the machine pulley and raise the thread take-up (1) before threading the upper thread.

This will make threading easier and it will prevent the thread from coming out at the sewing start.

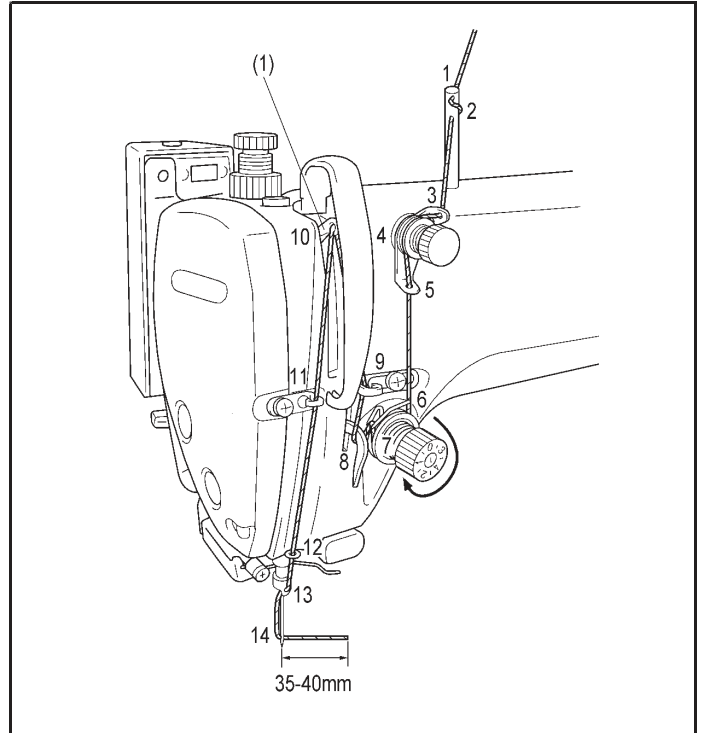

3-6 Adjusting the stitch length

1. Press the stitch button (1).
 2. Turn the stitch length dial (2) clockwise or counter clockwise so that the desired stitch length is at the upper most position on the dial.
- The larger the number, the longer the stitch length will be. (The numbers on the dial are for use as a guide. The length of the finished stitches may vary depending on the type and thickness of material being sewn. Adjust while looking at the finished stitches.)
 - When turning the stitch length dial (2) from a larger setting to a smaller setting, it will be easier to turn the dial if the reverse lever (3) is pushed to the halfway-down position.
3. Release the stitch button (1).
- Check that the stitch length dial (2) does not rotate.

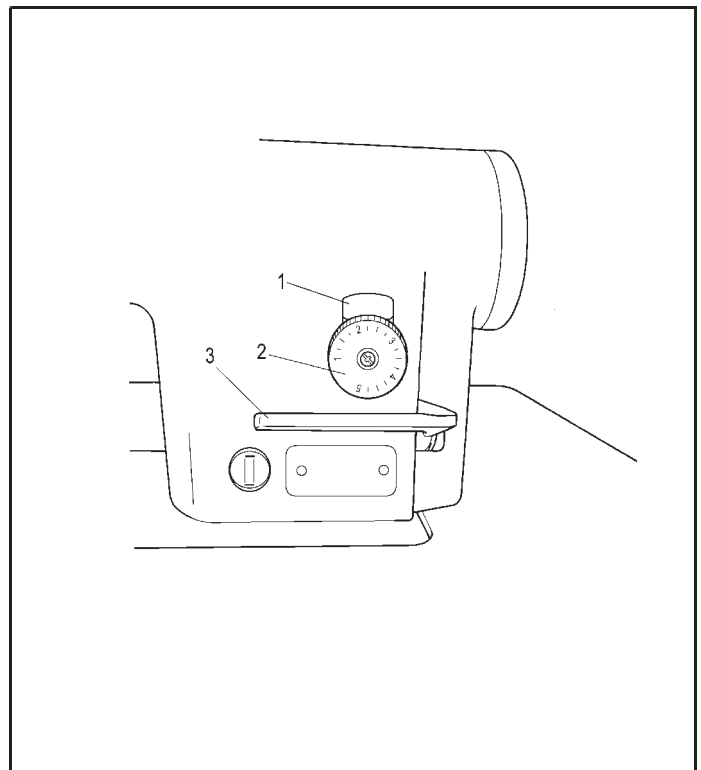

3-7 Using the thread wiper

Press the thread wiper switch (1) to the side. If this is done, the thread wiper (2) will operate after the thread is trimmed.

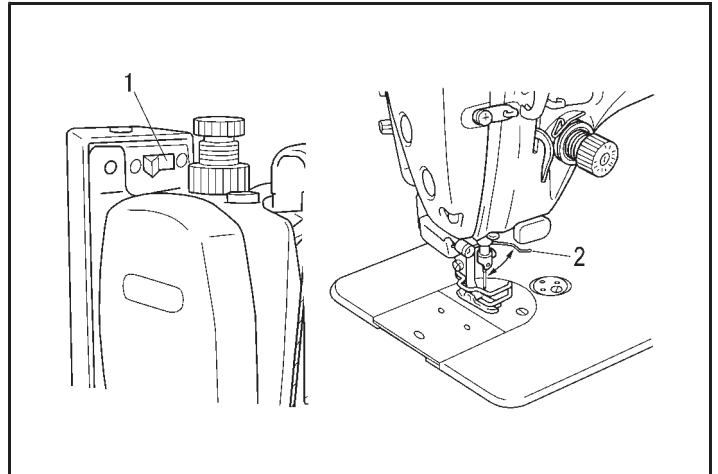

3-8 Using the knee lifter

The presser foot (2) can be raised by pressing the knee lifter plate (1).

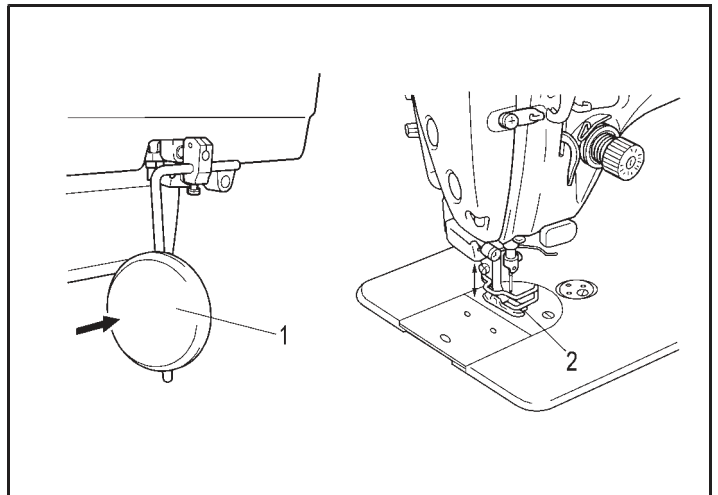

4. SEWING



CAUTION



Attach all safety devices before using the sewing machine. If the machine is used without these devices attached, injury may result.



Turn off power switch at the following times.

The machine may operate if the treadle is depressed by mistake, which could result in injury.

- When threading the needle.
- When replacing the bobbin and needle
- When not using the machine and when leaving the machine unattended.



Do not touch any of the moving parts or press any objects against the machine while sewing, as this may result in personal injury or damage to the machine.



Use both hands to hold the machine head when tilting it back or returning it to its original position. If only one hand is used, the weight of the machine head may cause your hand to slip, and your hand may get caught.

4-1. Sewing

1. press the ON power switch (1).
The power indicator (2) will illuminate.
2. Use the operating panel to carry out the programming which is necessary for sewing.
(Refer to the chapter on using the operating panel.)
3. Depress the treadle to start sewing.

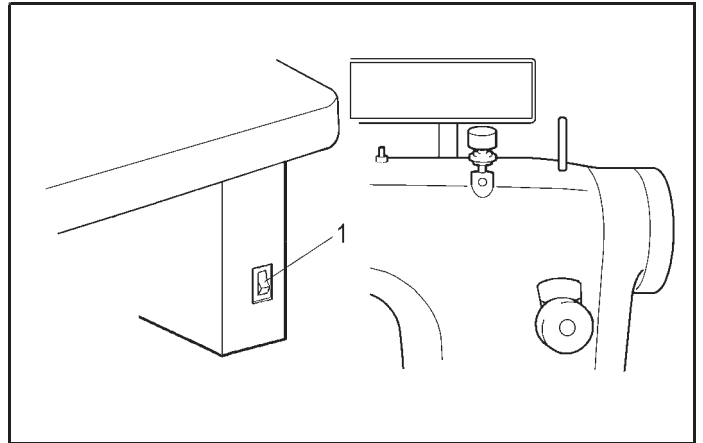

4-2. Backtacking

When the actuator (1) or the reverse lever (2) is pressed during sewing, the feed direction will be reversed. When it is released, the feed direction will return to normal.

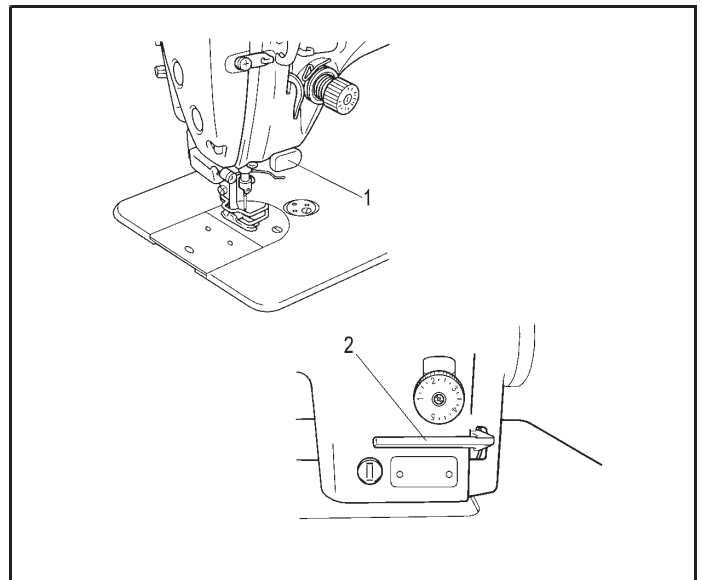

4-3. Sewing condensed stitches

- If you press the actuator (1) or the reverse lever (2) while sewing is in progress, you can sew stitches (forward direction) with small stitch lengths.
- Before carrying out sewing, set the stitch length for condensed stitches as follows.

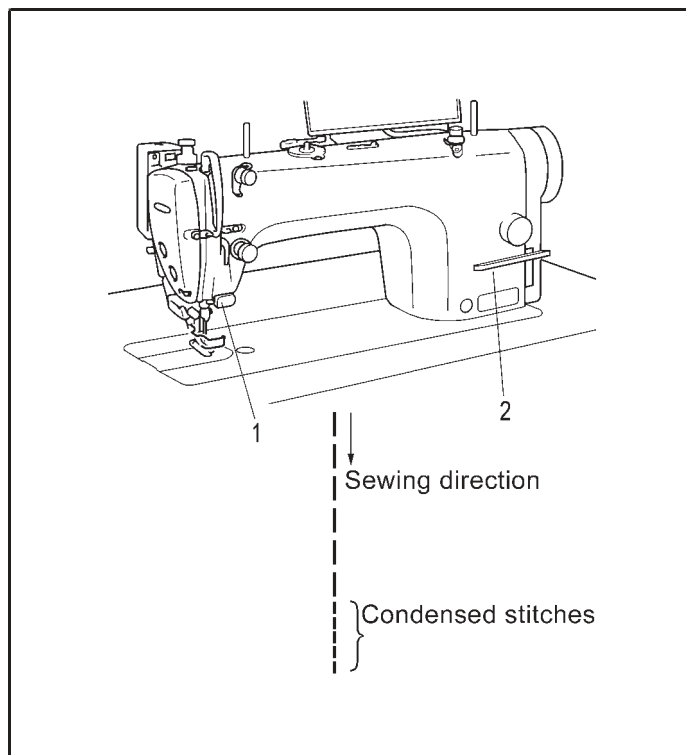

<Setting>

1. Press the stitch button (3).
2. Turn the stitch length dial (4) to the stitch length to be used for condensed stitches.
3. Release the stitch button (3), tilt back the machine head.
4. Loosen the nut (5) and then turn the bolt (6) until its head is touching the solenoid lever (7).
5. Tighten the nut (5) to secure the bolt(6).
6. Return the machine head to its normal position.

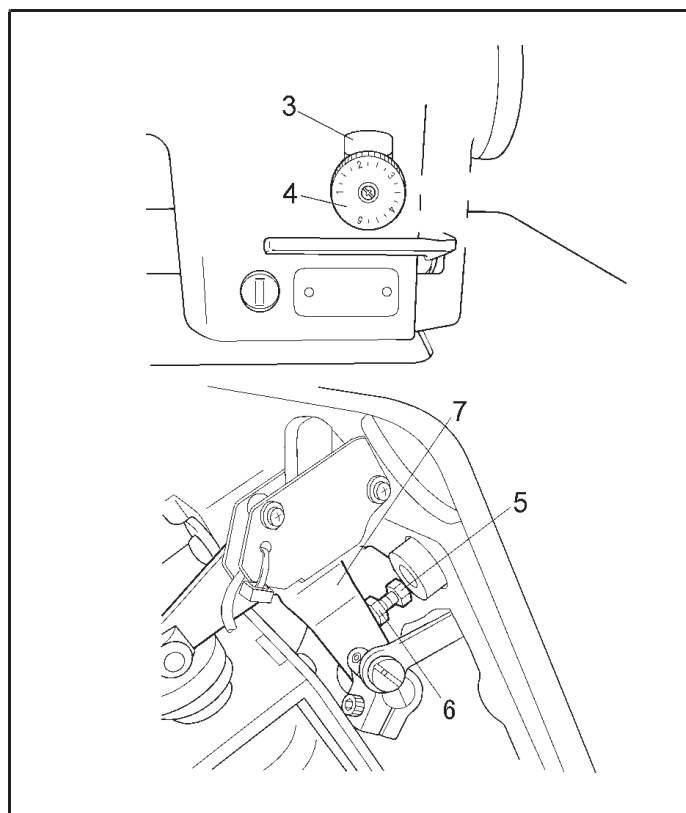

<Sewing>

1. Press the stitch button (3), return the stitch length dial (4) to the stitch length for normal sewing.
2. Release the stitch button (3).
3. Start sewing.
4. At the position where you would like to start sewing condensed stitches, press the actuator (1) or the reverse lever(2)

(Condensed stitches are sewn while the actuator (1) or reverse lever (2) is being pressed.)

* To stop sewing condensed stitches, tighten the bolt (6) so that its head is not touching the solenoid lever(7).

5. THREAD TENSION

5-1. Adjusting the thread tension



Turn off the power switch before removing or inserting the bobbin case.
The machine may operate if the treadle is depressed by mistake, which could result in injury.

Good even stitches.



← Upper thread
← Lower thread

Upper thread tension too weak or lower thread tension too strong.

Increase the upper thread tension.
Decrease the lower thread tension.

Upper thread tension too strong or lower thread tension too weak.

Decrease the upper thread tension.
Increase the lower thread tension.

< Lower thread tension >

Adjust by turning the adjustment screw (1) until the bobbin case drops gently by its own weight while the thread end coming out of the bobbin case is held.

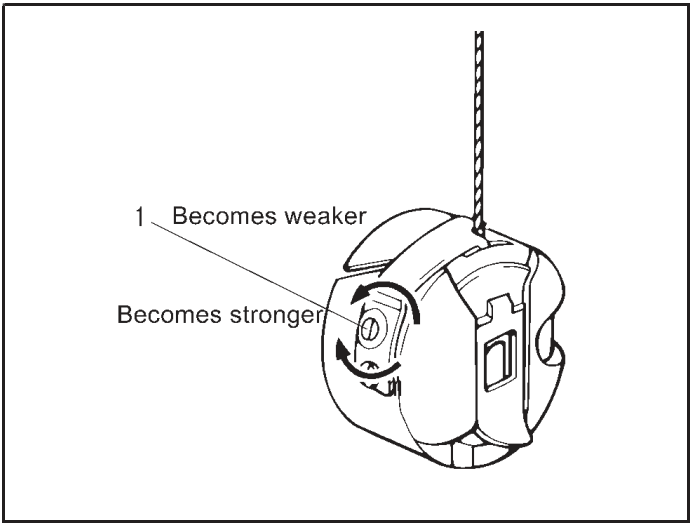

<Upper thread tension >

After the lower thread tension has adjusted, adjust the upper thread tension so that a good, even stitch is obtained.

1. Lower the presser foot,
2. Adjust by turning the tension nut(2).

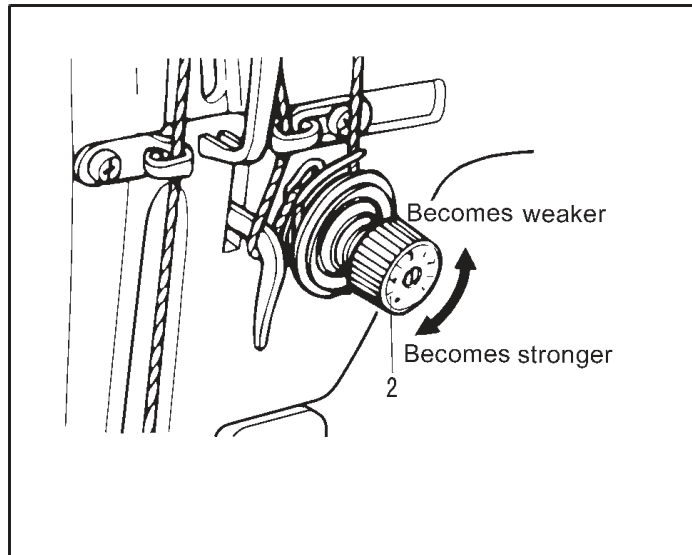

5-2. Adjusting the presser foot pressure

Correct stitches

 Upper thread

 Skipped stitches occur

 Uneven stitch length

→ Increase the pressure.

 Stitches are puckered

→ Decrease the pressure.

The presser foot pressure should be as weak as possible, but strong enough so that the material does not slip.

1. Loosen the adjusting nut (1).
2. Turn the presser adjusting screw (2) to adjust the presser foot pressure.
3. Tighten the adjusting nut (1).

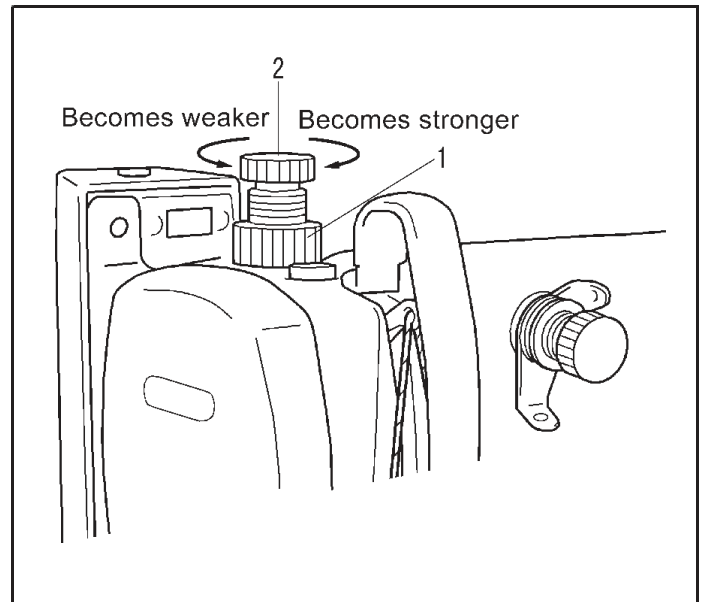

5-3. Adjusting the trailing length after thread trimming

- At the time of thread trimming, the thread tension is loosened and tension is applied by the pretension (1) only.
 - The standard trailing length for the upper thread is 35–40 mm.
 - If the tension of the pretension (1) is increased, the lengths of the threads trailing from the needle tips will be reduced; if the tension is reduced, the lengths will be increased.
- Adjust by turning the pretension(1).

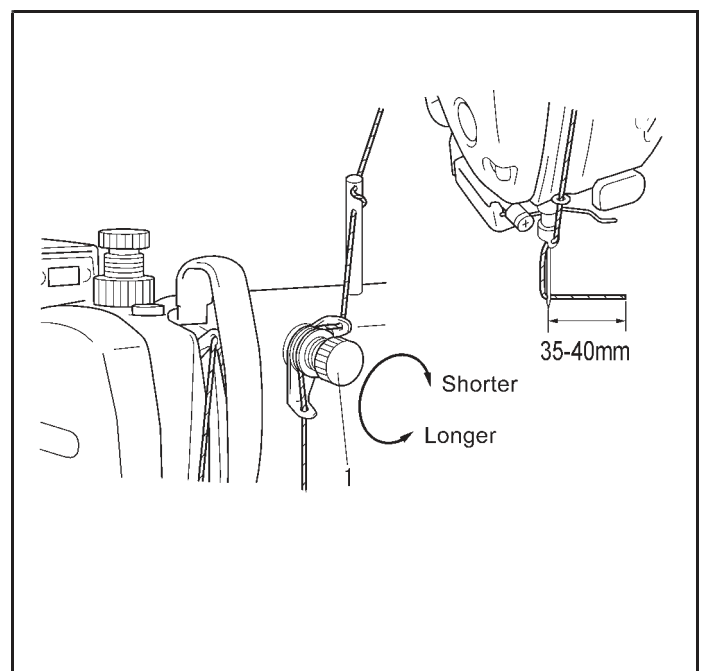

6.CLEANING



CAUTION



Turn off the power switch before carrying out cleaning.
The machine may operate if the treadle is depressed by mistake, which could result in injury.



Be sure to wear protective goggles and gloves when handling the lubrication oil and grease, so that they do not get into your eyes or onto your skin, otherwise inflammation can result.
Furthermore, do not drink the oil or eat the grease under any circumstances, as they can cause vomiting and diarrhea.
Keep the oil out of the reach of children.



Use both hands to hold the machine head when tilting it back or returning it to its original position, if only one hand is used, the weight of the machine head may cause your hand to slip, and your hand may get caught.

6-1.Daily cleaning procedures

the following cleaning operations should be carried out each day in order to maintain the performance of this machine and to ensure a long service life.

Furthermore, if the sewing machine has not been used for a long period of time, carry out the following cleaning procedures before using it again.

1. Cleaning

1. Raise the presser foot.
2. Remove the two screws (1), and then remove the needle plate(2).
3. Use a soft wire brush to clean any dust from the feed dog (3).
4. Install the needle plate(2) with the two screws (1).

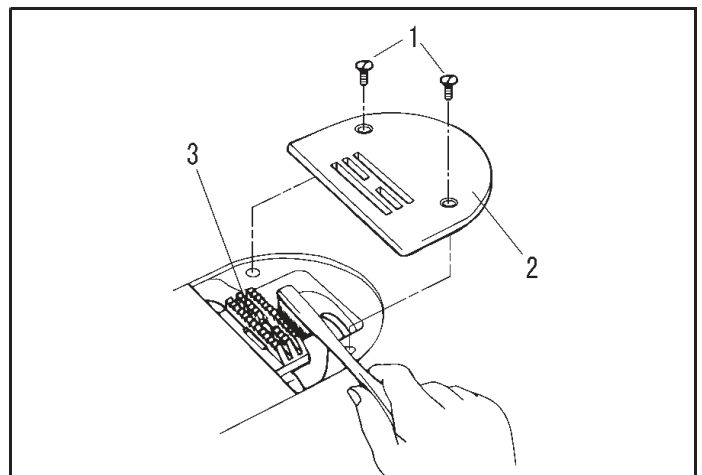

5. Tilt back the machine head.
6. Remove the bobbin case (4).
7. Wipe off any dust from the rotary hook (5) with a soft cloth, and check that there is no damage to the rotary hook (5).
8. Remove the bobbin from the bobbin case (4) and clean the bobbin case (4) with a cloth.
9. Insert the bobbin into the bobbin case (4) and then place the bobbin case (4) back into the machine.

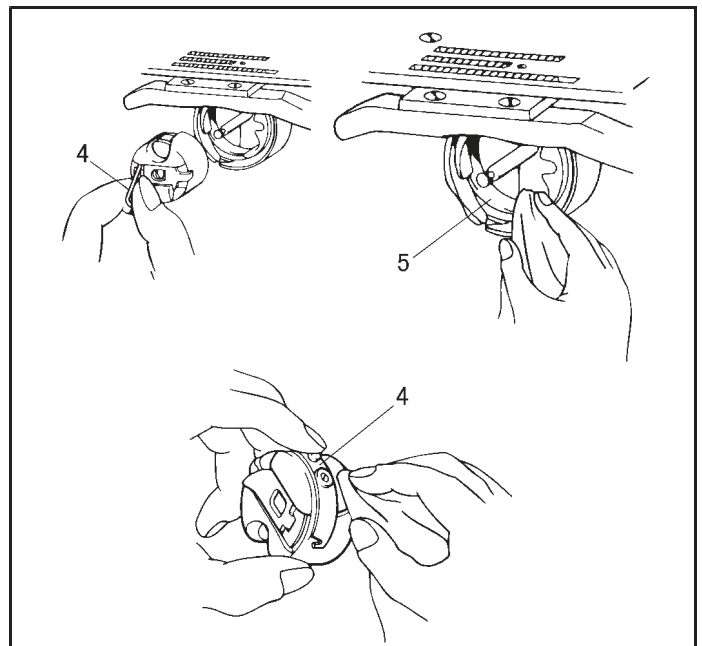

2. Lubrication

A. Gearbox oil quantity

NOTE:

•Check the quantity of oil in the gearbox immediately after tilting back the machine head.

When the machine head is left for long periods in the tilted-back position, the amount of oil in the felt inside the gearbox drops and the oil level seen from the oil windows (1) rises, so that it becomes impossible to measure the actual oil level accurately.

•The position of the oil level in the oil window (1) will vary depending on the angle of the machine head.

Tilt back the machine head while the head rest (2) is installed in the correct position as shown in the table processing dia-gram .

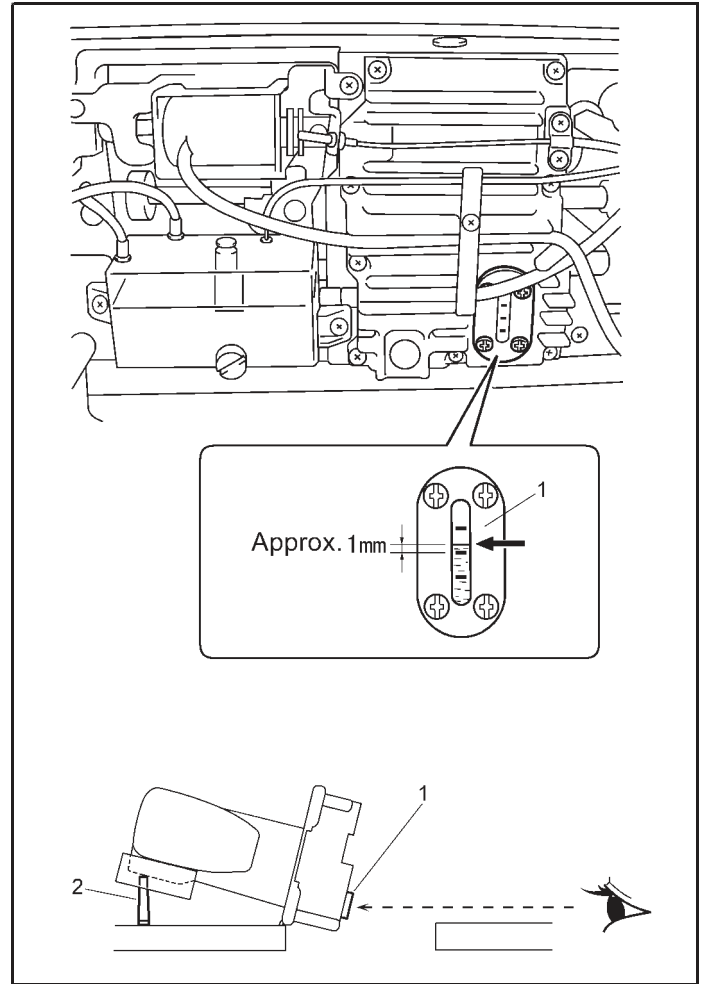

<Checking the oil quantity>

The oil level should normally be approximately 1 mm above the center reference line in the oil window (1). (70 ml of lubricating oil is added to the gearbox at the time of shipment from the factory.)

1. Look at the oil window (1) from directly in front.
2. If the oil level is below the normal level, add more lubricating oil as described in the following procedure.

<Lubrication>

Use only the lubricating oil specified by our company.

1. Remove the rubber cap (3).
2. Add lubricating oil until the oil level is approximately 1 mm above the center reference line in the oil window (1).
Do not pour all of the lubricating oil in at once at this time.
Pour the lubricating oil 10 ml at a time while checking the oil window (1).

NOTE:

Do not pour too much lubricating oil into the specified location.

If too much oil is added oil leaks may result.

3. Insert the rubber cap (3) securely.
4. Return the machine head to its original position.

NOTE:

The rubber cap (3) has a hole in it for adjusting the air pressure.

When replacing the rubber cap (3) use only the replacement part specified by our company.

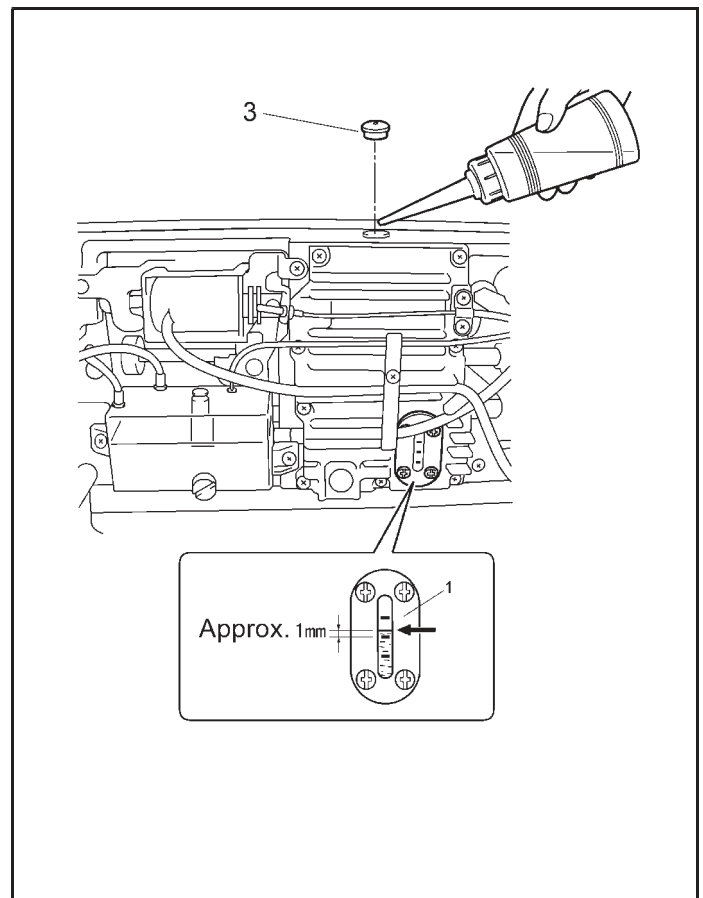

B. Oil tank oil quantity.

Check the oil gauge window (1), and add more oil if the oil gauge (2) is below the lower reference line.

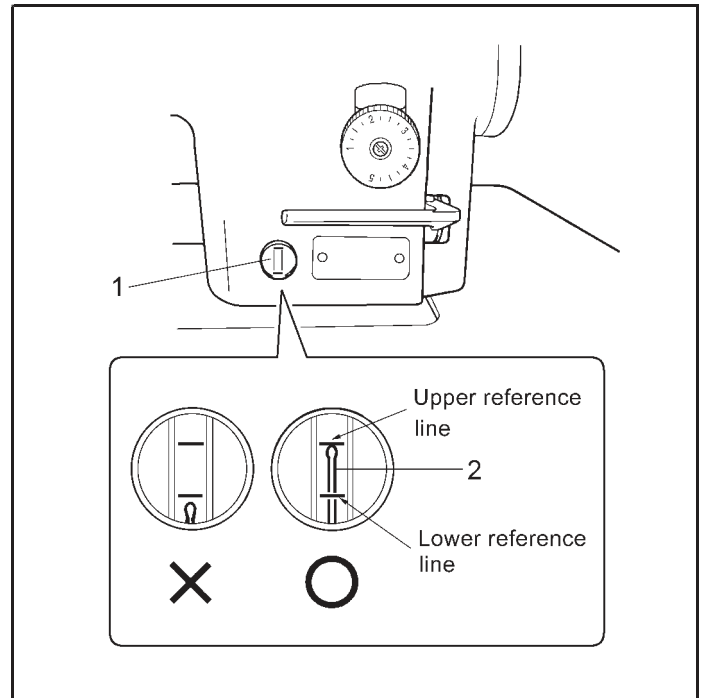

3. Checking

1. Replace the needle if it is bent or if the tip is broken.
2. Check that the upper threads have been threaded correctly.
3. Carry out a test sewing.

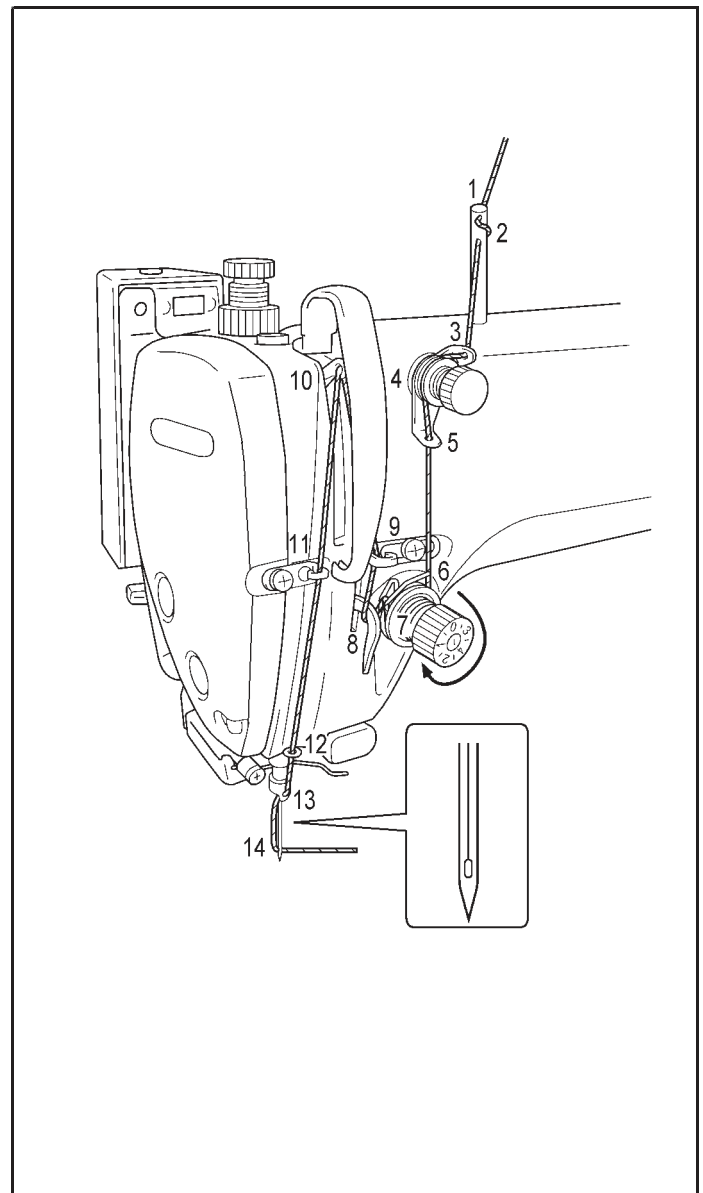

6-2. Applying grease

<Applying grease>

Use our company specified grease.

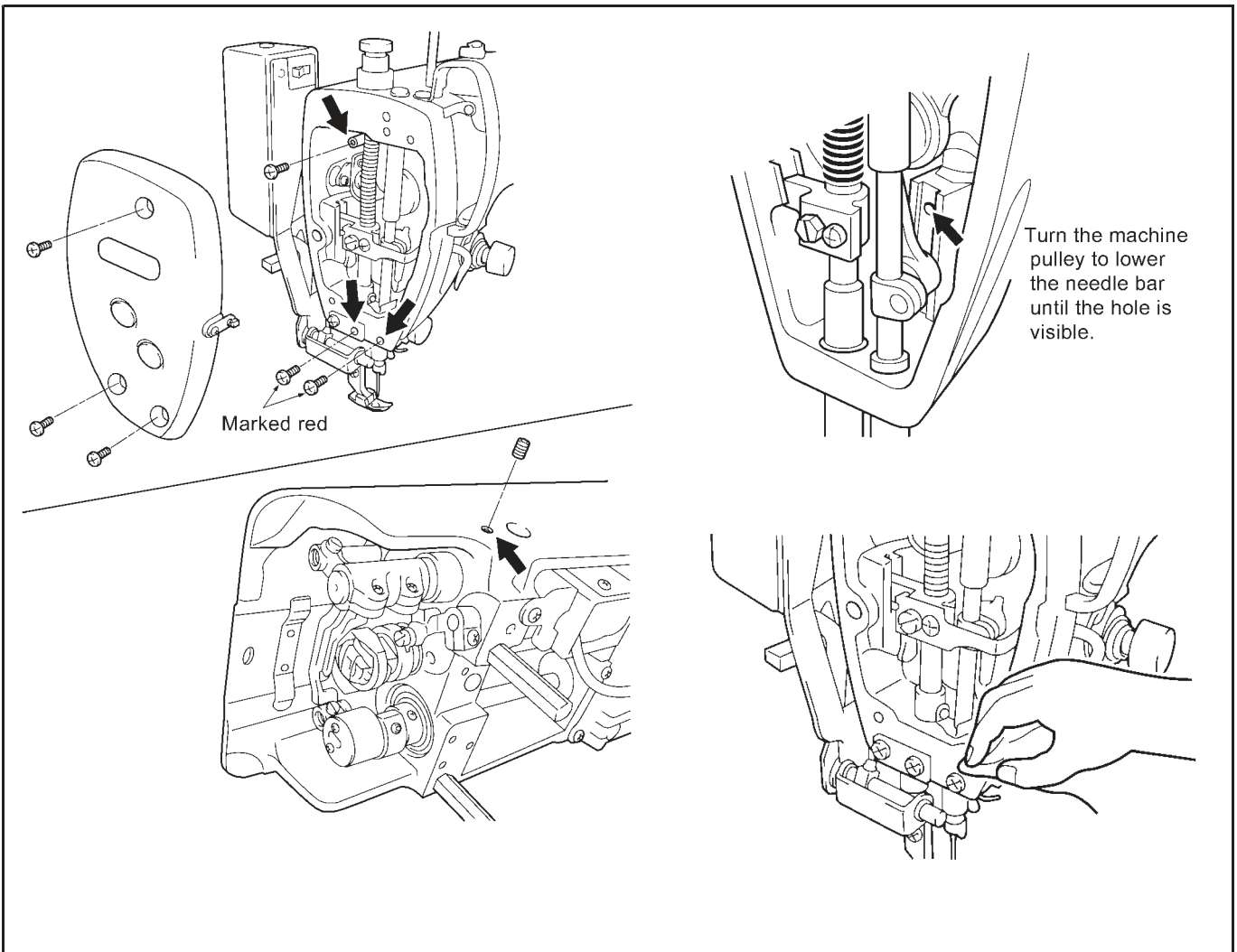
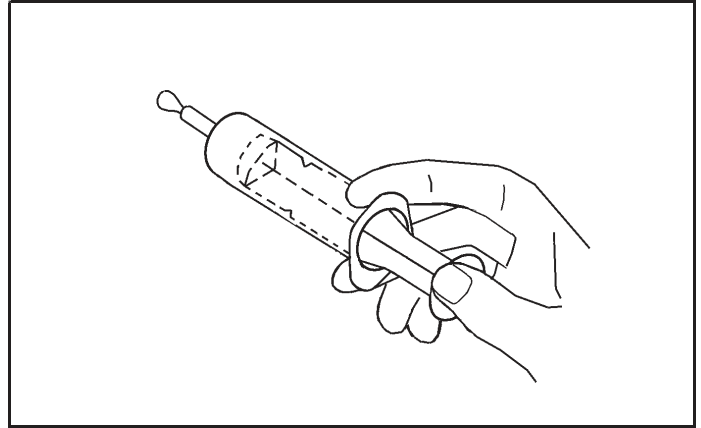

1. Turn the power switch to "OFF"
2. Remove the screws and the set screws.
3. Apply grease to each of the holes until the grease overflows slightly.
4. Tighten the screws and the set screws in order to push the grease in.
5. Turn the machine pulley by hand to move the needle bar up and down several times in order to disperse the grease.
6. Use a cloth to wipe away any excess grease from around the screws and set screws and from underneath needle bar bush D.
7. Carry out the reset procedure given below.

7. ADJUSTING THE ROTARY HOOK LUBRICATION AMOUNT



Be careful not to touch your fingers or the lubrication amount check sheet against moving parts such as the rotary hook or the feed mechanism when checking the amount of oil supplied to the rotary hook, otherwise injury may result.

Use the following procedure to check the amount of oil being supplied to the rotary hook when replacing the rotary hook or when changing the sewing speed.

<Checking the lubrication amount>

1. Remove the thread from all points from the thread take-up to the needle.
2. Use the lifting lever to lift the presser foot.
3. Run the machine at the normal sewing speed for approximately 1 minute without sewing any material (following the same start/stop pattern as when actually sewing).
4. Place the lubrication amount check sheet (1) underneath the rotary hook (2) and hold it there. Then run the sewing machine at the normal sewing speed for 8 seconds. (Any type of paper can be used as the lubrication amount check sheet (1).)
5. Check the amount of oil which has spattered onto the sheet.

If adjustment is necessary, carry out the following operations in "Adjusting the lubrication amount".

Note:

If the lubrication amount does not match the correct amount shown in the illustration at left (if the amount of spattered oil is too much or none at all), turn the adjusting screw (3) clockwise to fully tighten it, turn it back counterclockwise by 2 1/2 turns, and then carry out the following adjustment.

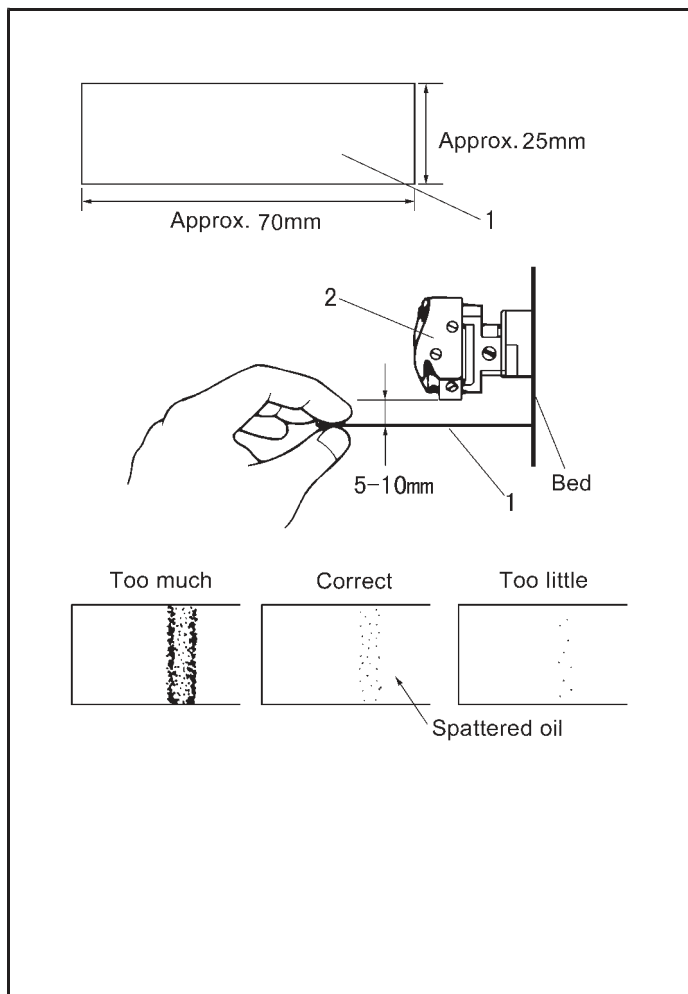



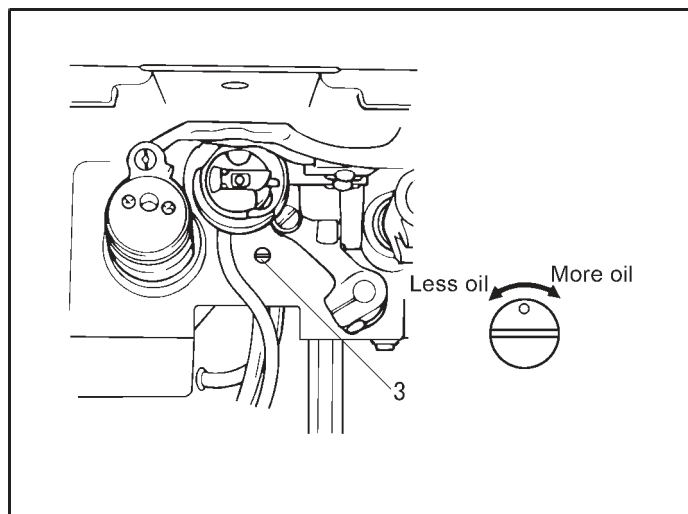

<Adjusting the lubrication amount>

1. Tilt back the machine head.
 2. Turn the adjusting screw (3) to adjust the lubrication amount.
- If the rotary hook adjusting screw (3) is turned clockwise, the lubrication amount becomes greater.
 - If the rotary hook adjusting screw (3) is turned counterclockwise, the lubrication amount becomes smaller.
3. Check the lubrication amount again according to the procedure given in "Checking the lubrication amount" above.
 - * Turn the adjusting screw (3) and check the lubrication amount repeatedly until the lubrication amount is correct.
 4. Check the lubrication amount again after the sewing machine has been used for approximately two hours.



8. STANDARD ADJUSTMENTS

⚠ CAUTION

-  Maintenance and inspection of the sewing machine should only be carried out by a qualified technician.
-  Ask your dealer or a qualified electrician to carry out any maintenance and inspection of the electrical system.
-  If any safety devices have been removed, be absolutely sure to re-install them to their original positions and check that they operate correctly before using the machine.
-  Use both hands to hold the machine head when tilting it back or returning it to its original position. If only one hand is used, the weight of the machine head may cause your hand to slip, and your hand may get caught.



Turn off the power switch and disconnect the power cord from the wall outlet at the following times, otherwise the machine may operate if the treadle is depressed by mistake, which could result in injury.

- When carrying out inspection, adjustment and maintenance
- When replacing consumable parts such as the rotary hook and knife



If the power switch needs to be left on when carrying out some adjustment, be extremely careful to observe all safety precautions.

8-1. Adjusting the safety switch position

The safety switch (1) is normally installed as shown in figure [A].

However, if the processing method used for the table leaves too much space between the machine head and the table hole, it may adversely affect the operation of the safety switch (1)

<Adjustment method>

The standard amount of clearance between the machine head and the table hole is 1.5mm.

If the clearance is 3.5mm or more, install the safety switch (1) so that the washer (2) is on the machine head side as shown in Figure[B].

If the position cannot be satisfactorily adjusted in this way, add more washers of the same thickness.

<Safety switch operation>

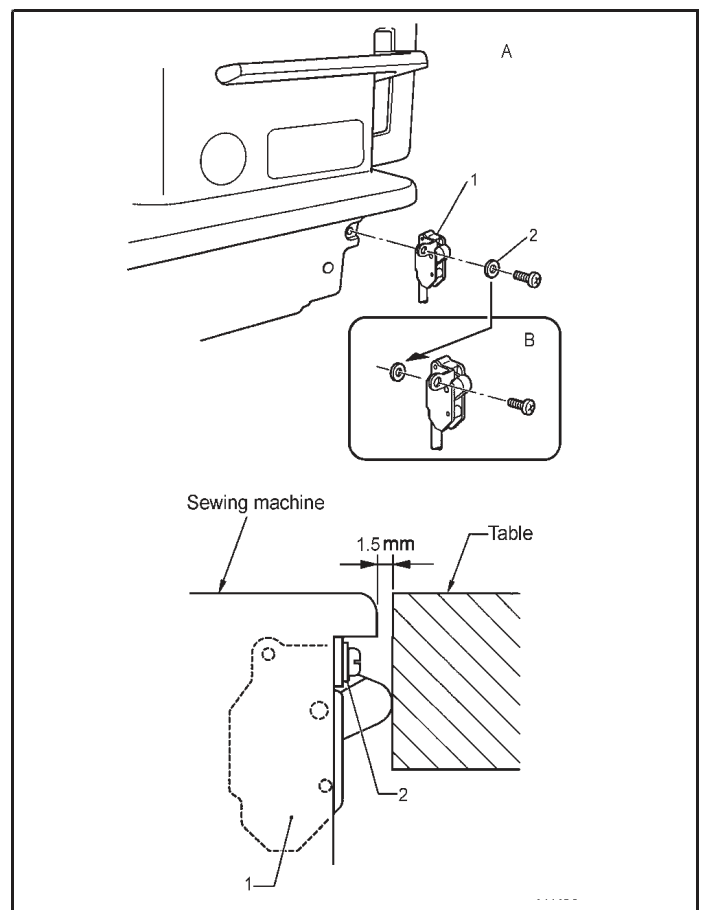
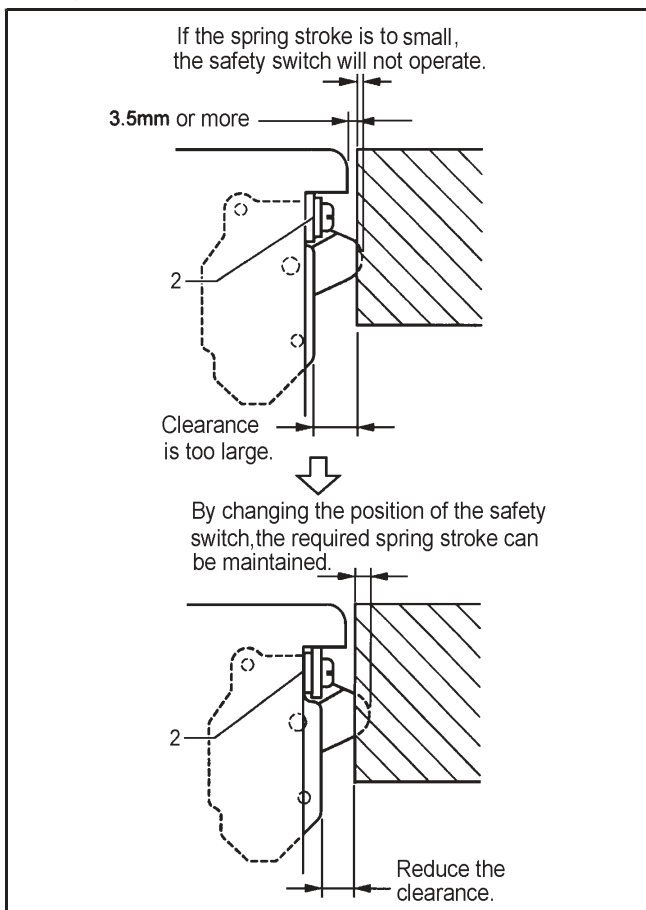

8-2. Adjusting the thread take-up spring

<Thread take-up spring position>

The standard position of the thread take-up spring (1) is 6~8mm [4~6mm for H、B specifications] above the surface of the thread guide(3) when the presser foot (2) is lowered.

1. Lower the presser foot (2).
2. Loosen the set screw (4).
3. Turn the thread tension bracket (5) to adjust the spring position.
4. Securely tighten the set screw (4).

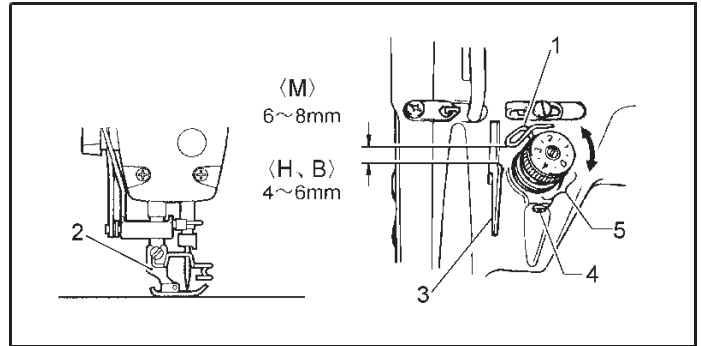

<Thread take-up spring tension>

The standard tension of the thread take-up spring (1) varies in accordance with the machine specifications as shown in the table.

M	0.25~0.35N
H、B	0.30~0.5N

1. Push the needle thread with your finger until it is slightly higher than the thread tension bracket (5) and so that the upper thread is not pulled out.
2. Pull the upper thread down until the thread take-up spring (1) is at the same height as the base of the thread guide (3), and then measure the tension of the thread take-up spring (1).
3. Insert a screwdriver into the slot of the tension stud (6), and turn the screwdriver to adjust the tension of the thread take-up spring (1).

NOTE:

If using the tension gauge (7) (sold separately) to measure the tension, take the reading from the scale on the side of the red line.

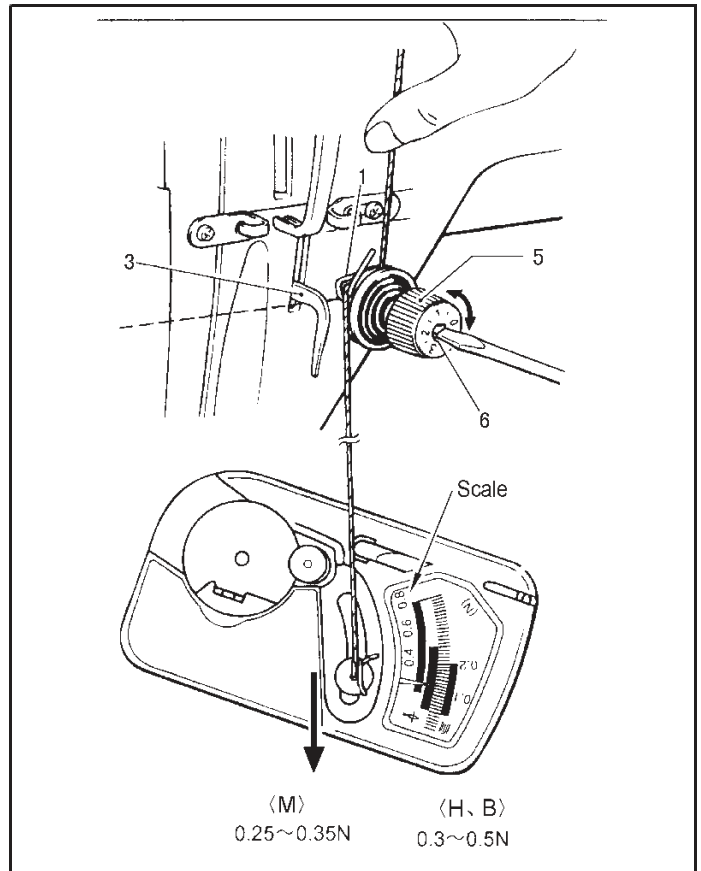

8-3. Adjusting arm thread guide R

The standard position of arm thread guide R (1) is the position where the screw (2) is in the center of the adjustable range for arm thread guide R(1).

To adjust the position, loosen the screw (2) and then move arm thread guide R(1).

- When sewing thick material, move arm thread guide R(1) to the left. (The thread take-up amount will become greater.)
- When sewing thin material, move arm thread guide R(1) to the right. (The thread take-up amount will become less.)

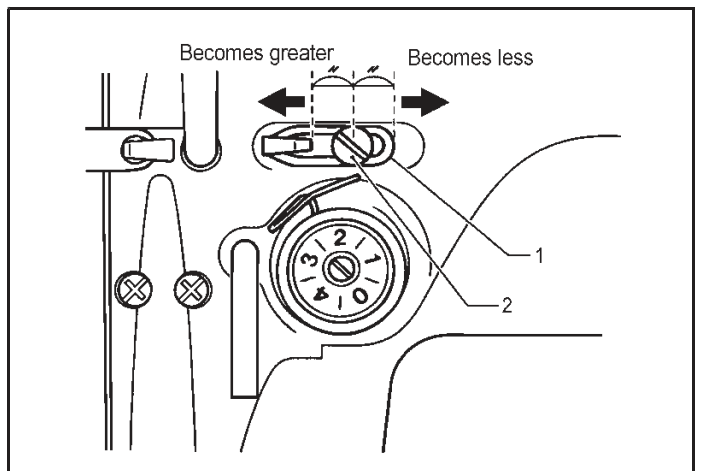

8-4. Adjusting the presser foot height

The standard height of the presser foot (1) is 6mm when the presser foot (1) is raised by means of the lifting lever (2).

1. Loosen the nut (3) of the adjustment screw (4), and then turn the adjustment screw (4) so that there is no pressure applied to the presser foot.
2. Raise the lifting lever (2). The presser foot (1) will also rise.
3. Remove the oil cap (5).
4. Loosen the screw (6) and then move the presser bar (7) up or down until the presser foot (1) is at the standard height of 6mm.
5. Tighten the screw (6).
6. Replace the oil cap (5).
7. Adjust the presser foot pressure using the adjustment screw (4), and then tighten the nut (3).

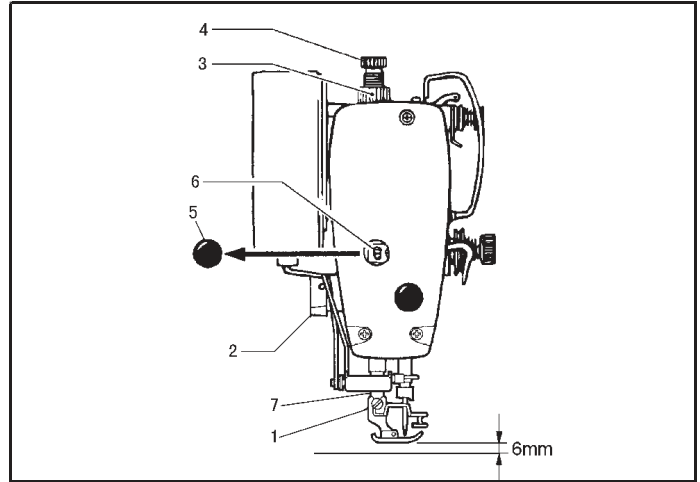

8-5 . Adjusting of the feed dog height

The standard height of the feed dog (1) when it is at its maximum height above the top of the needle plate is 1.0 mm for M specifications, and 1.2mm for H, B specifications.

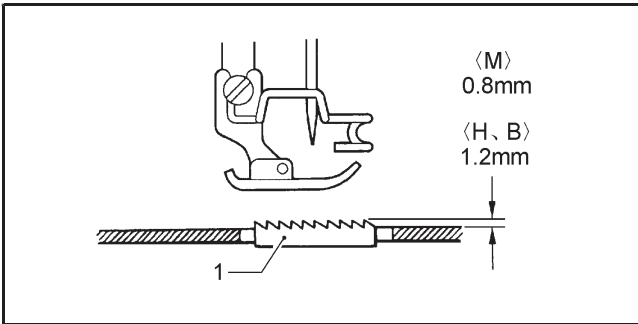

1. Turn the pulley until the feed dog (1) rises to the highest position.
2. Tilt back the machine head.
3. Loosen the screw (2).
4. Turn the feed lifting rock bracket stud (3) within a range of 90° from the reference line (4) to adjust the vertical height of the feed bar (5) (Fig. [A]).
5. Tighten the screw (2).

If you are worried about the angle of the feed dog (1), turn the shaft (6) while carrying out the above adjustment, (Fig. [B]).

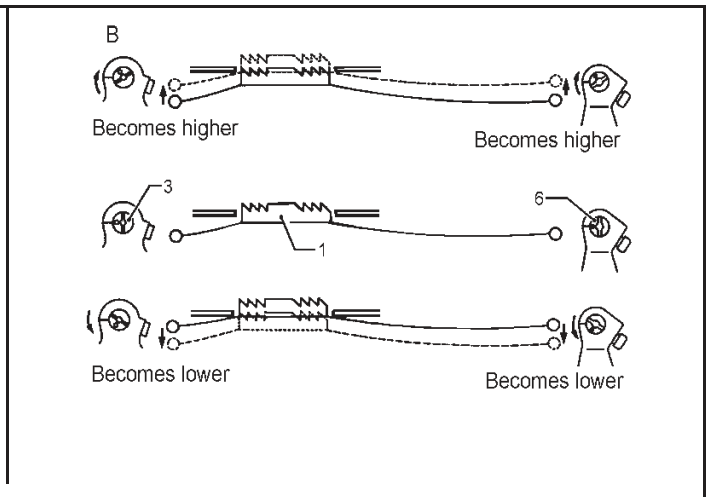
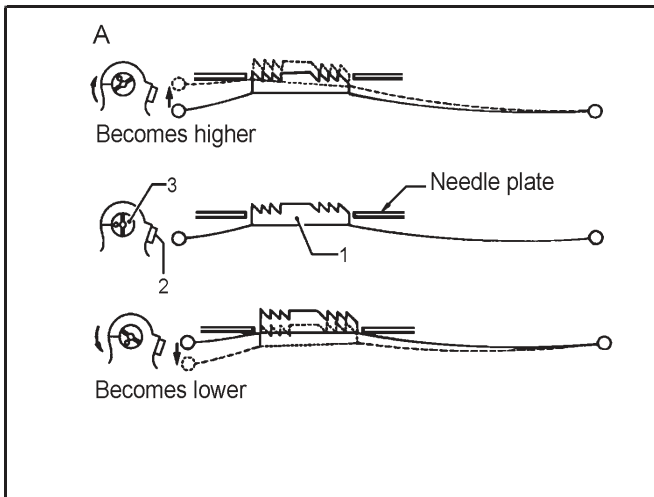
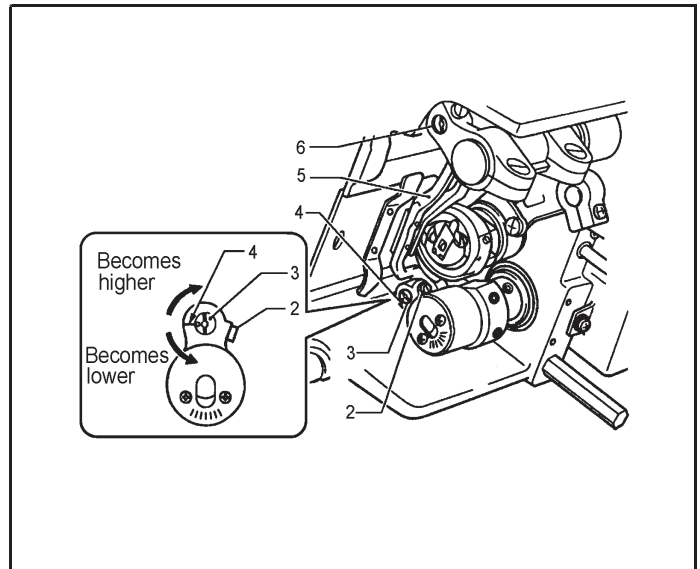

8-6 .Adjusting the feed dog angle

The standard angle of the feed dog (1) on the top of needle plate is subject to the ○ mark (or V mark) on the cloth feeding short-axis (2) coincidence with the mark on parallel cloth feeding bracket, the feed dog(1) is paralleling with the needle plate

1. Turn the machine pulley forward to raise the feed dog (1) from its lowest position until it is flush with the top of the needle plate ,and stop turning the pulley at that point.
2. Tilt back the machine head.
3. Loosen the two set screws(4).
4. Turn the shaft (2) in the direction of the arrow within a range of 90°with respect to the standard position (Fig.[C])
 - * In order to prevent puckering , lower the front of the feed dog(1)
 - * In order to prevent puckering the material from slipping, raise the front of the feed dog(1)
5. Securely tighten the set screws(4).

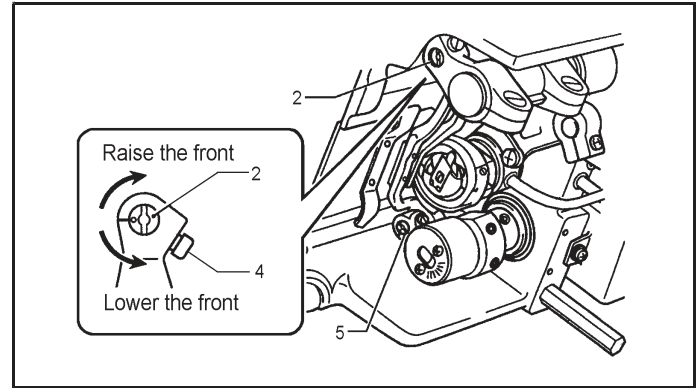

*If you would like to tilt the feed dog (1) further, turn the feed lifting rock bracket stud (5) while carrying out the above adjustment.(Fig.[D])

*The height of the feed dog (1) will change after the angle has been adjusted, so it will be necessary to readjust the height of the feed dog(1).

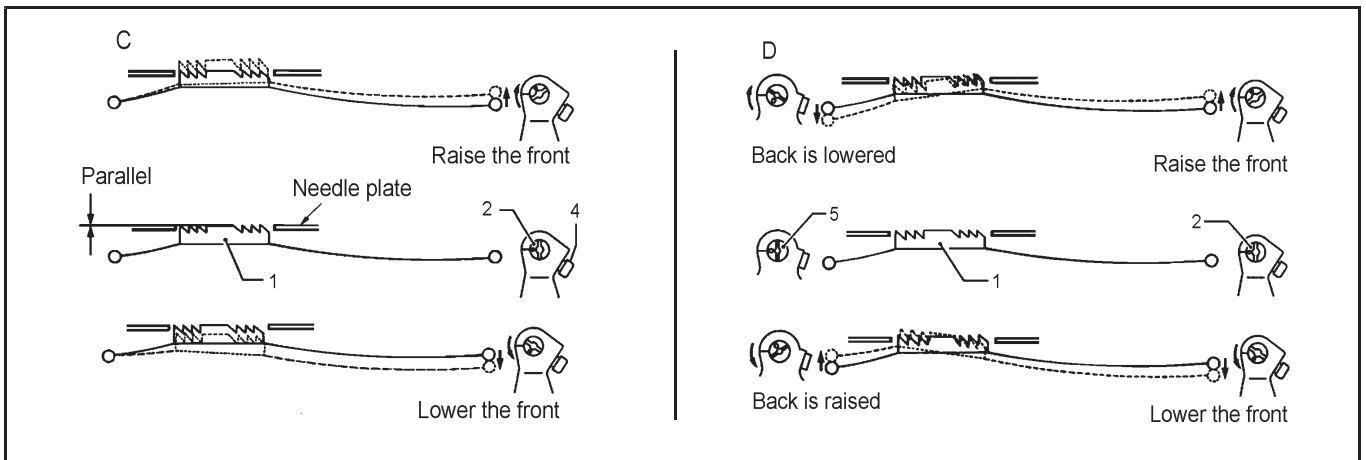

8-7 Adjusting the needle bat height

Adjust so that the distance from needle bar mounting surface A to the bottom edge of needle bar bushing (2) is the same as the height of surface B on the <1> side of the accessory timing gauge (2) when the needle bar (1) is at its lowest position as shown in the illustration.

1. Turn the machine pulley to set the needle bar (1) to its lowest position.
2. Remove the rubber cap (3) from the face plate.
3. Loosen screw (4) to adjust the needle bar(1) .
4. Securely tighten the screw(4).
5. Install the rubber cap (3).

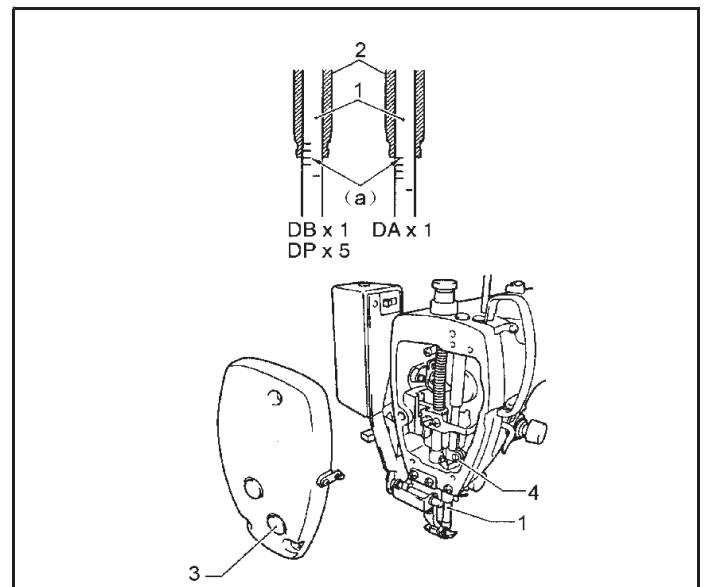

8-8 .Adjusting the needle and feed mechanism timing

The standard timing is for the tip of the needle to be in the position given below when the machine pulley is turned forward to raise the feed dog (1) from its lowest position until it is flush with the top of the needle plate (2).

(At this time, the "-" mark on the lower shaft will be aligned with the center of the scale (4) ("O" mark) on the vertical cam (3).

<M> There is gap of approximately 1mm between the tip of the needle and the top of the needle plate(2).

<H,B> There is gap of approximately 3mm between the tip of the needle and the top of the needle plate(2).

1. Tilt back the machine head.

2. Loosen the two set screws (5), and then turn the vertical cam (3) slightly to adjust the timing.

* If transferred to standard, rotating the eccentric (3) to make the mark (O) with the mark (-). (Fig.[A])

* In order to prevent overlapping stitching when the fabric is inconsistent [suture sub], the machine needle timing adjustment later. (Upper and lower eccentric (3) to (B) the direct ion of rotation Fig [B])

* In order to close good stitch, can be adjusted earlier machine needle. (Upper and lower eccentric(3) to (C) the direct ion of rotation Fig [C])

NOTE: The upper and lower eccentric (3) to (C) over the direction of rotation, is caused by Broken Needle reasons.

3. After adjustment is completed , securely tighten the two screws(5).

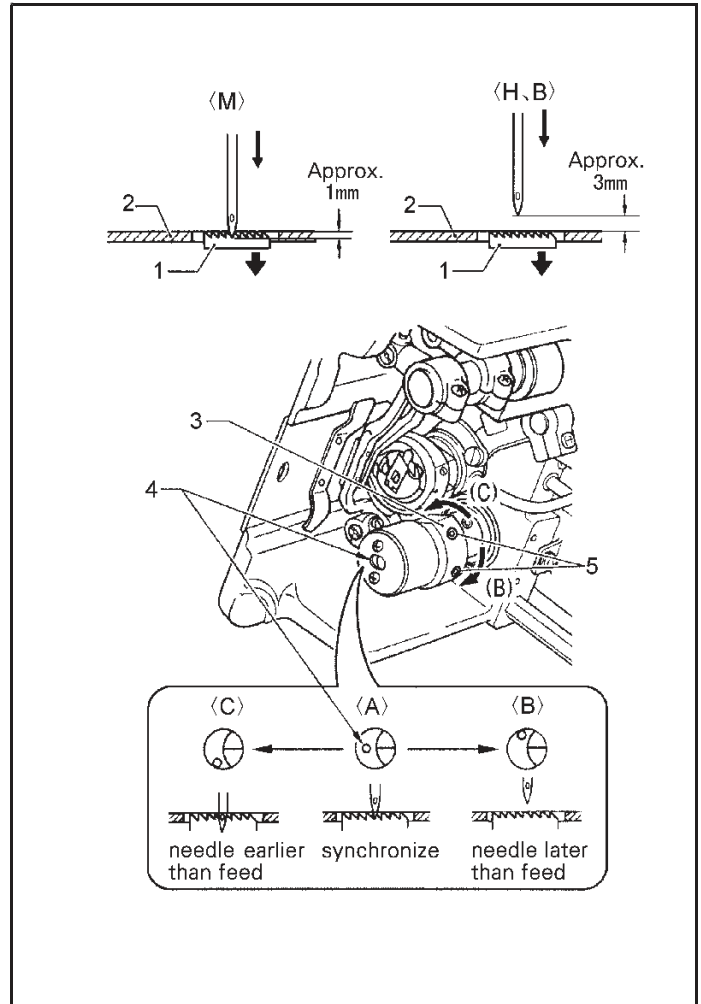

8-9. Adjusting the needle and rotary hook timing

When the needle bar (1) rose from the lowest position of 1.8mm (H,B specification is 2.2mm), as shown, baseline (b) with the needle bar bushings (2) to maintain alignment of the lower end, the hook tip (3) and the center of the needle (4) must be consistent.

(At this time , the gap between the upper edge of the needle hole and the rotary hook tip (3) will be 0.5-0.7mm)

1. Turning sewing machine handwheel, so that the needle bar (1) from the lowest up to, as shown in the baseline fig, baseline (b) with the needle bar bushings (2) to maintain alignment of the lower end.

2. Loosen the remaining set screw(5), and align the rotary hook tip(3) with the center of the needle(4). There should be a gap of 0-0.5mm between the rotary hook tip (3) and the needle (4) at the time.

3. Securely tighten the screw(5).

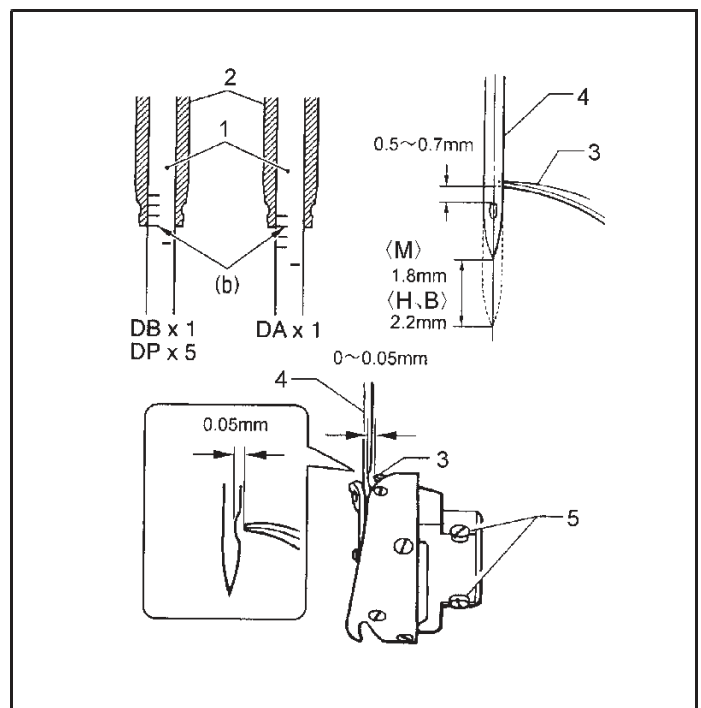

<Checking the clearance between the rotary hook and bobbin case holder position bracket >

Check that the clearance between the rotary hook (8) and the bobbin case holder position bracket (10) is enough to allow the thread being used to pass through smoothly. The clearance should be 0.4–0.7mm for M models, and 0.6–1.1 mm for H、B models.

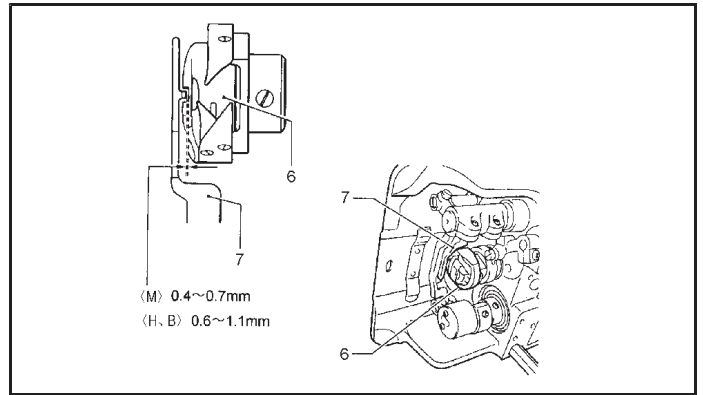

8-10. Adjusting the treadle

<Forward depression sensitivity adjustment >

If the machine starts running at low speed when your foot is simply resting on the treadle, or if the treadle pressure is felt to be too weak, adjust the position (a to c) at which the treadle spring (1) is hooded onto the treadle lever (2).

a is the weakest position and it becomes gradually stronger at b and c respectively.

<Backward depression sensitivity adjustment >

1. Loosen the nut (3) and the bolt (4).

When the bolt (4) is tightened, the treadle operation becomes heavier, and when it is loosened, the operation becomes lighter.

2. Tighten the nut (3).

<Adjusting the treadle stroke>

Remove the nut (5), and then move the connecting rod joint (6) from the position in figure A to the position in figure B. The treadle stroke will then be increased by approximately 27%.

At this time, the treadle forward and backward depression sensitivity will change, so readjust if necessary.

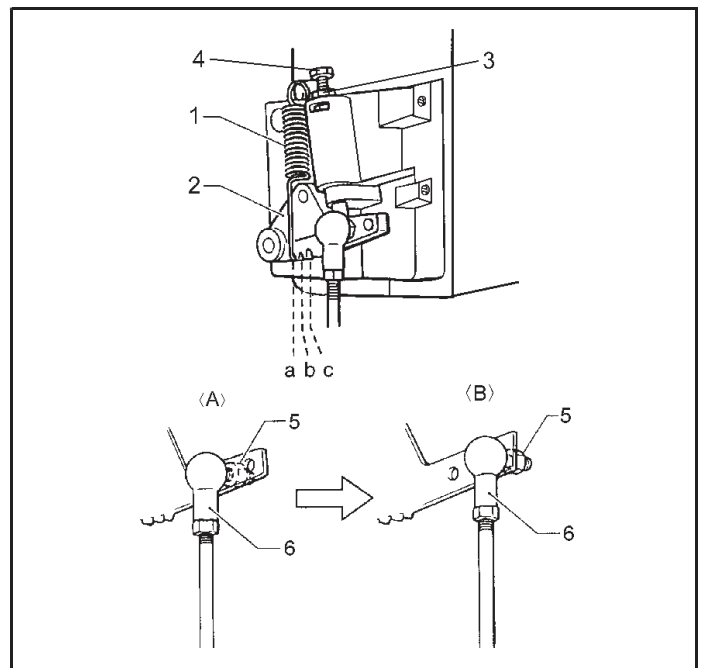

8-11. Adjusting the presser foot floating amount (minute lifting amount)

When sewing stretch materials and materials with long pile, you can make minute adjustments to the floating amount for the presser foot (1) in accordance with the material.

1. Turn the sewing machine pulley by hand to move the feed dog (2) below the needle plate (3).

2. Use the lifting lever to lower the presser foot (1).

3. Loosen the nut (4).

4. Use a screwdriver to turn the adjustment screw (5) to adjust the floating amount.

● To raise the presser foot (1)

Turn the adjusting screw (5) clockwise.

● To lower the presser foot (1)

Turn the adjusting screw (5) counterclockwise.

5. Tighten the nut (4).

After making the adjustment, sew a piece of material to check the floating amount.

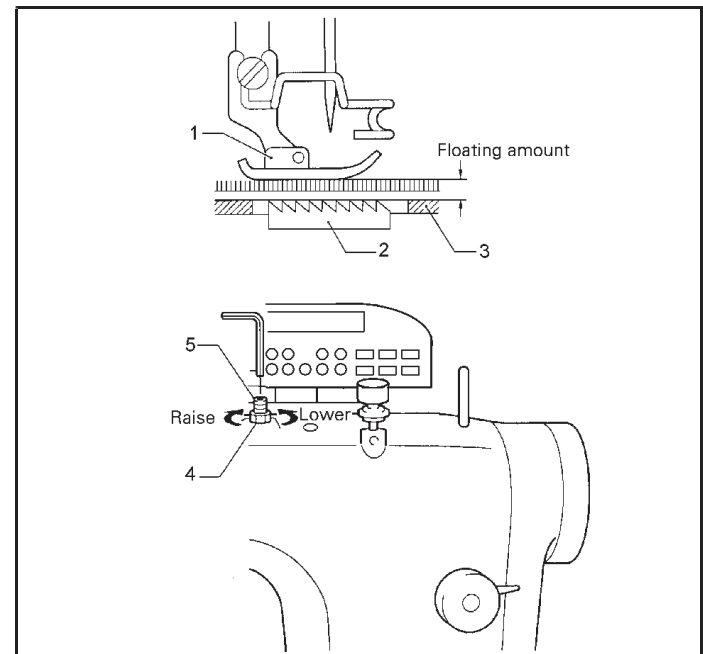

8-12. Adjusting the tangent timing

1. The position of the tangent cam adjustment

Turn the handwheel of sewing machine, when the needle bar from the bottom up 5 mm, hand on a tangent electromagnet (4), Make roller shaft and the cam tangent (1) of the gap in contact, Then use fastening screw (2) to temporary fixation.

Will the tangent electromagnet (4) return to its original position (leave position), loosen the screw move (2), Adjustment tangent cam (1), the space of cam head face and roller shaft head face is 0.6-0.8mm , Tighten lock screw (2).

【With about 40 kg/cm torque force tightened the screw】

2. Sword and fixed knife position adjustment

Adjust the tangent cam roller (3) and hook side of crank shaft at about 3 mm outside, To tighten the screws (8), Use a hand to mesh electromagnet, Make sure that the maximum amount engagement, The fixed knife (6) front moving across the blade (5) is not more than mouth raised portion .If the mesh is appropriate, should be loosen screws (8), Adjust the tangent cam roller (3) and crank shaft of the hook on the right outside the gap and makes dynamic meshing quantity requirements for the sword of the position, and then screw (8).

【With about 40 kg/cm torque force to tighten the screws】

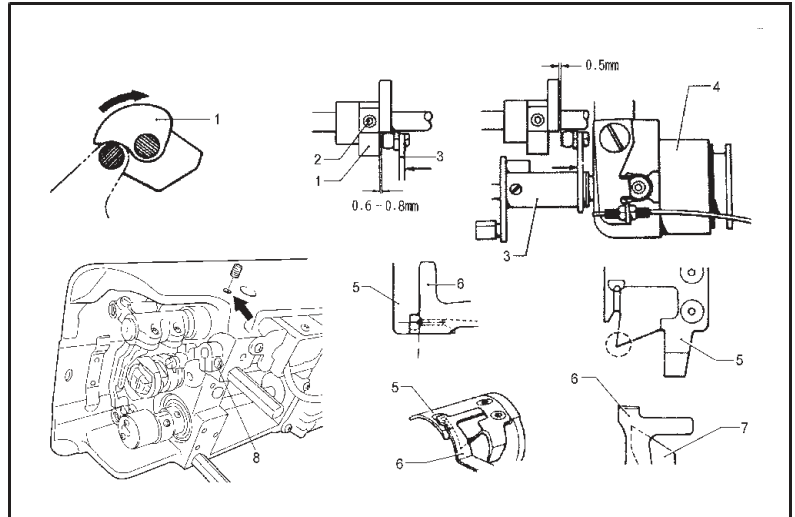

8-13. Adjusting pick the thread take up the amount

Note:

in addition to M type beyond, do not use this function.

When sewing thick object, if will pick for a large number of thread take up set numerical, the line will be easier to adjust the tension.

1. Dismantling the panel.
2. Remove rubber stopple (1).
3. Use hex wrench (3), Will screw (2) and (3) to loosen 2 weeks.

4. Adjust the amount pick the thread take up line.
 < When to increase the pick of the thread take up line >
 Will pick the thread take up hinge axis (4) clockwise rotation, make slot (5) just up.

<When need to pick the thread take up line returned to the amount of the standard>

Will pick the thread take up hinge axis (4) according to counterclockwise rotation, make slot (5) just down..

5. The thread take up the challenges hinge axis (4) pushed to the most inside of the state, the first screws (2) twist to pick

the thread take up hinge axis (4) of the screw installation on the plane.

6. And then, turn screws (3).
7. Put on rubber stopple (1).
8. Installation on the panel.

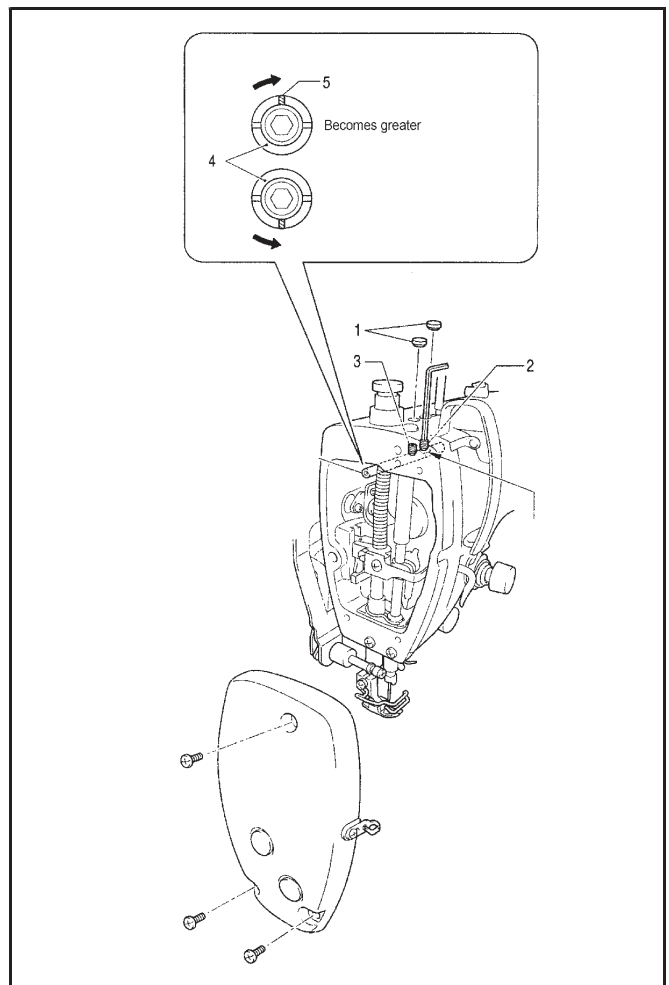







9. TROUBLESHOOTING

- Please check the following points before calling for repairs or service.
- If the following remedies do not fix the problem, turn off the power switch and consult a qualified technician or the place of purchase.

⚠ DANGER
 <p>Wait at least 5 minutes after turning off the power switch and disconnecting the power cord from the wall outlet before opening the face plate of the control box. Touching areas where high voltages are present can result in severe injury.</p>

⚠ CAUTION
 <p>Turn off the power switch and disconnect the power cord before carrying out troubleshooting. The machine may operate if the treadle is depressed by mistake, which could result in injury.</p>

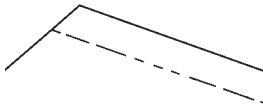
Problem	Possible cause
<p>1.Upper thread is not tight.</p> 	<ul style="list-style-type: none"> ● Is the upper thread tension too weak, or is the lower thread tension too strong? Adjust the upper thread tension or lower thread tension.
<p>2.Lower thread is not tight.</p> 	<ul style="list-style-type: none"> ● Is the lower thread tension too weak, or is the upper thread tension too strong? Adjust the lower thread tension or upper thread tension.
<p>3.Loops appear in seam.</p> 	<ul style="list-style-type: none"> ● Is the thread path not smooth enough? Use a file with a fine grain or sandpaper to polish smooth the thread path. ● Is the bobbin not turning smoothly? Pull out the lower thread to check that there is no slackness in the thread tension, or replace the bobbin or bobbin case.
<p>4.Skipped stitches occur while sewing</p> 	<ul style="list-style-type: none"> ● Is the needle tip bent? Is the needle tip blunt? If the needle tip is bent or broken, replace the needle. ● Is the needle properly installed? If it is incorrect, install the needle correctly. ● Is the machine properly threaded? If it is incorrect, thread the thread correctly. ● Is the presser foot pressure too weak? Adjust the presser foot pressure. ● Is the needle too thin? Replace the needle with a needle that is one rank thicker. ● Is the presser foot too high? Adjust the height of the presser foot. ● Is the thread take-up spring too weak? Adjust the tension of the thread take-up spring.

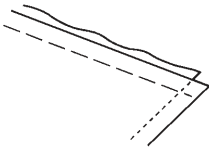
Problem	Possible cause
<p>5. Skipped stitches at sewing start Thread unravelling at sewing start</p> 	<ul style="list-style-type: none"> ● Is the thread take-up spring tension too strong? Reduce the tension of the thread take-up spring. ● Is the thread take-up spring operating range too large? Lower the position of the thread take-up spring. ● Are the trailing lengths of the upper threads too short after thread trimming? Adjust the pretension. ● Are the threads not being trimmed cleanly? Sharpen the fixed knives, or replace the fixed and movable knives if necessary. ● Is the needle too wide? Try using a needle with a count that is one lower than the current needle. ● Is the length of thread trailing out from the bobbin case after thread trimming too short? If the bobbin is spinning loosely, replace the anti-spin spring in the bobbin case. ● Is the sewing speed too fast at the sewing start? Use the slow start feature.
<p>6. Uneven seam</p> 	<ul style="list-style-type: none"> ● Is the presser foot pressure too weak? Adjust the presser foot pressure. ● Is the feed dog too low? Adjust the feed dog height. ● Is the bobbin scratched? If the bobbin is damaged, smooth it with an oiled grindstone or replace it.
<p>7. Large degree of puckering (excess tension)</p> 	<ul style="list-style-type: none"> ● Is the upper thread tension too strong? Make the upper thread tension as weak as possible. ● Is the lower thread tension too strong? Make the lower thread tension as weak as possible. ● Are the thread take-up spring tensions too strong? Make the thread take-up spring tension as weak as possible. ● Is the thread take-up spring operating range too large? Lower the position of the thread take-up spring to as low a position as possible. ● Is the presser foot pressure too strong? Adjust the presser foot pressure. ● Is the sewing speed too fast? Use the sewing speed control keys to gradually reduce the sewing
<p>8. Material slippage</p> 	<ul style="list-style-type: none"> ● Is the presser foot pressure too strong? Adjust the presser foot pressure.

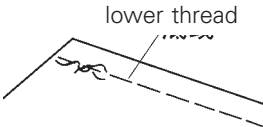
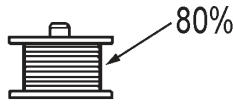
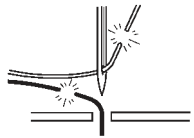
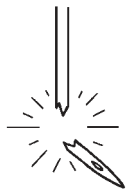
Problem	Possible cause
<p>9. Lower thread is tangled at the sewing start. Spinning of bobbin during thread trimming</p> 	<ul style="list-style-type: none"> ● Is the bobbin spinning direction correct when the lower thread is being pulled? Set the bobbin so that it turns in the opposite direction to the rotary hook. ● Is there too much thread wound onto the bobbin? The bobbin winding amount should not be more than 80%. ● Is the anti-spin spring attached? Attach the anti-spin spring. ● Is the bobbin turning smoothly? If the bobbin is not turning smoothly, replace the bobbin 
<p>10. Upper and lower threads are breaking.</p> 	<ul style="list-style-type: none"> ● Is the needle bent or is the needle tip broken? Replace the needle if it is bent or broken. ● Is the needle properly installed? If it is incorrect, install the needle correctly. ● Is the machine properly threaded? If it is incorrect, thread the thread correctly. ● Is the rotary hook sufficiently lubricated? If the oil gauge is down to the lower reference line in the oil gauge window, add more oil. ● Is the upper or lower thread tension too weak or too strong? Adjust the upper thread or lower thread tension. Is the upper thread may be loose because the thread take-up spring operating range is too small? ● Adjust the position of the thread take-up spring. Is the rotary hook, feed dog or other part damaged? ● If they are damaged, smooth them with an oiled grindstone or replace the damaged parts. ● Is the thread path damaged? If the thread path is damaged, smooth it with sandpaper or replace the damaged part.
<p>11. Incorrect thread trimming (Upper and lower threads are both not being trimmed)</p>	<ul style="list-style-type: none"> ● Is the fixed knife or movable knife damaged or worn? Replace the fixed knife or the movable knife.
<p>12. Incorrect thread trimming (upper thread or lower thread is not being trimmed)</p>	<ul style="list-style-type: none"> ● Is the needle properly installed? If it is incorrect, install the needle correctly. ● Is the fixed knife or movable knife blunt? Replace the fixed knife or the movable knife.
<p>13. Broken needles</p> 	<ul style="list-style-type: none"> ● Is the material being pushed or pulled with excessive force during sewing? ● Is the needle properly installed? If it is incorrect, install the needle correctly. ● Is the needle bent, is the needle tip broken, or is the needle hole blocked? Replace the needle. <p>Caution</p> <div style="border: 1px dashed black; padding: 5px;"> <ul style="list-style-type: none"> • It is extremely dangerous to leave any pieces of broken needle sticking in the material • If the needle breaks, search for all pieces until the whole of the needle is found again. • Furthermore, we recommend we recommend that through steps be taken to account for such needles to comply with product liability regulations. </div>

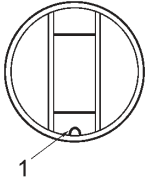
Problem	Possible cause
<p>14.Oil gauge (1)is not risible in oil gauge win – dow.</p> 	<ul style="list-style-type: none"> ● Is the oil tank empty? Fill the oil tank with oil.
<p>15.Machine does not operate when power is turned on and treadle is pressed.</p>	<ul style="list-style-type: none"> ● Is the power supply connector disconnected from the control box? Insert the connector securely.
<p>16. Machine does not operate at high speed.</p>	<ul style="list-style-type: none"> ● Is the sewing speed setting or backtack speed setting incorrect? Use the sewing speed control keys to set the high speed.
<p>17. Machine stops during sewing</p>	<ul style="list-style-type: none"> ● Is the fixed stitch key turned on? Press the fixed stitch key so that the indicator turns off. ● Is the power supply voltage too low? Check the power supply. (If the power cord is too long or too many appliances are being run from a single outlet, this may cause voltage drops which will in turn cause the reset function to activate and stop the machine, even if the power supply itself is normal.)
<p>18 .Nothing appears on the operation panel display.</p>	<ul style="list-style-type: none"> ● Is the power supply connector disconnected from the control box? Insert the connector securely. ● Is the operation panel connector inside the control box disconnected? Insert the connector securely.

1. MACHINE BODY

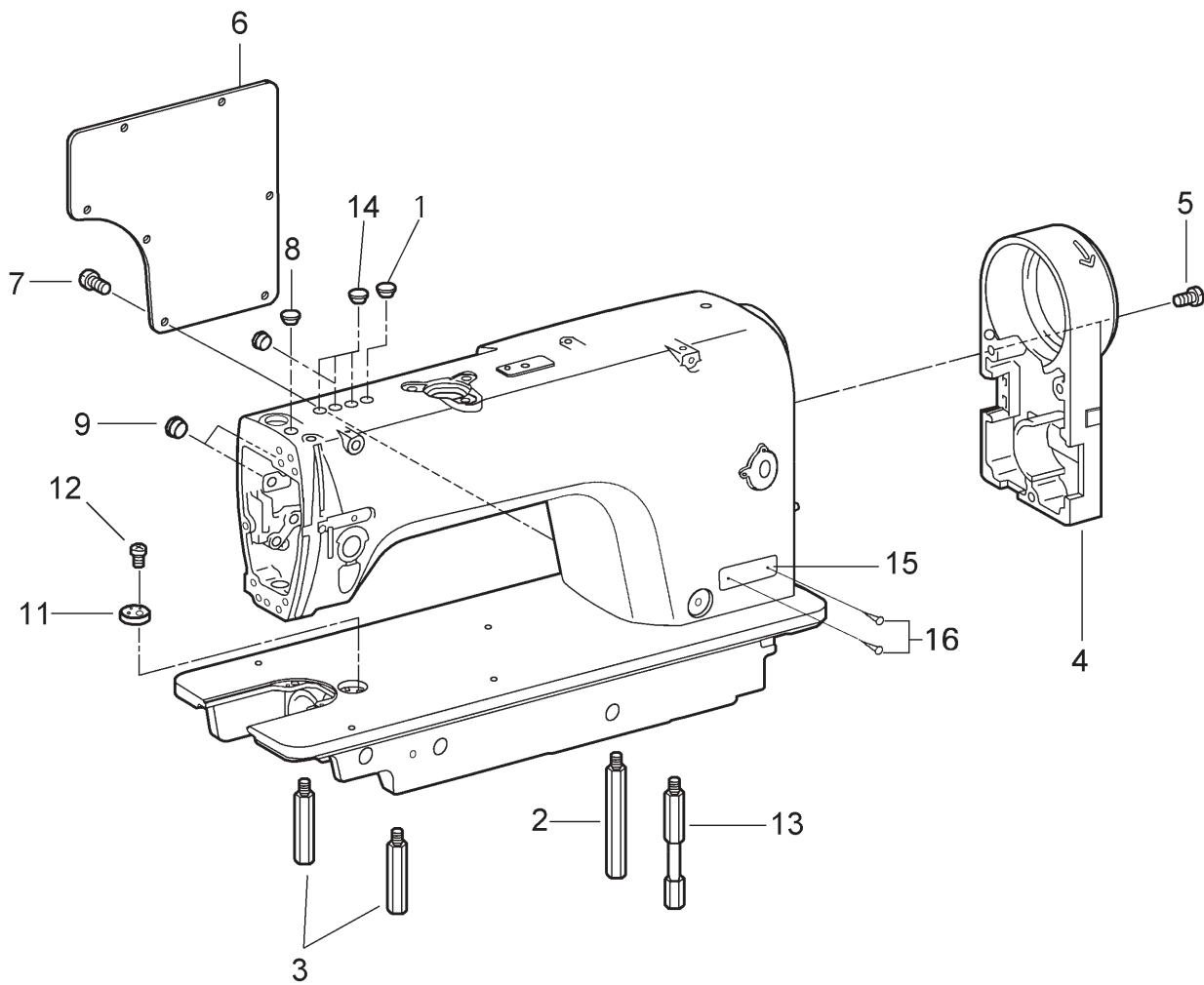

1. MACHINE BODY

No.	Ref.No.	Description	Qt	Note
1	BX78847009	Rubber cap Φ 8.5	1	
2	BXF9904009	Stand,R	1	
3	BXF9903009	Stand,L	2	
4	230100001	Motor cover	1	
5	S150216032	Screw M5x12	3	
6	BXF9905001	Side plate	1	
7	S150216032	Screw M5x12	7	
8	022200011	Rubber cap Φ 8.8	1	
9	230100019	Rubber cap 15.5	2	
11	BX01489959	Ruler plate	1	
12	B048600494	Screw M4x6	2	
13	BXF8930009	Stand, RF	1	
14	B906650909	Rubber cap 8	4	
15	198000020	Model plate	1	
15	198000021	Model plate	1	
16	BXF8899009	Rivet	2	

2. NEEDLE BAR AND THREAD TAKE-UP MECHANISM

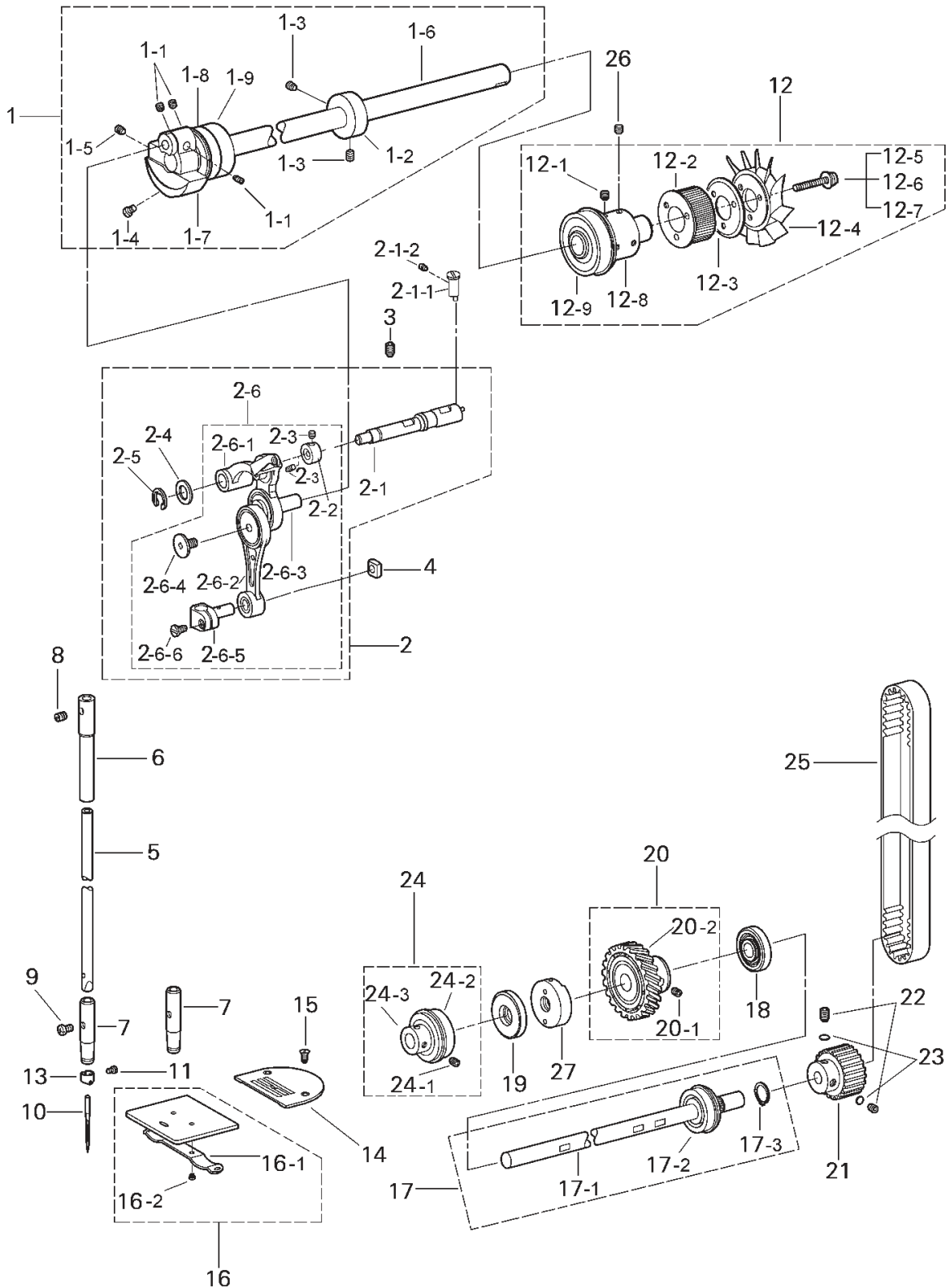

2. NEEDLE BAR AND THREAD TAKE-UP MECHANISM

No.	Ref.No.	Description	Qt	Note
1	230210000	Upper shaft assy	1	
1-1	BX87459009	Set screw M6x6	3	
1-2	BXF9980009	Bobbin winder driving wheel	1	
1-3	BX87459009	Set screw M6x6	2	
1-4	BX85875009	Screw M8	1	
1-5	BX85874009	Set screw M6x10	1	
1-6	217100012	Upper shaft	1	
1-7	230100015	Needle bar crank	1	M、H
	217100013	Needle bar crank	1	B
1-8	S150801008	Bearing 6004 2ZNR	1	
1-9	S150801006	Bearing 6004 2Z	1	
2		Needle bar conecting rod unit	1	M
		Needle bar conecting rod unit	1	H
		Needle bar conecting rod unit	1	B
2-1	217N00002	Thread take-up support shaft	1	
2-1-1	BXF3871909	Positioning pin	1	
2-1-2	B098500574	Screw M5x5	1	
2-2	BXF9985009	Tighten ring	2	
2-3	B098600674	Screw M4x4	1	
2-4	BXF8949009	Washer	1	
2-5	B062040768	Retaining ring E6	1	
2-6	230221100	Thread take-up lever assy	1	M
	230221200	Thread take-up lever assy	1	H
	230G21000	Thread take-up lever assy	1	B
2-6-1	BXF9970009	Thread take-up small lever assy	1	M
	BXF9983009	Thread take-up small lever assy	1	H
	230G21100	Thread take-up small lever assy	1	B
2-6-2	BXF8914009	Needle bar conecting rod set	1	M
	BXF8913009	Needle bar conecting rod set	1	H、B
2-6-3	230100016	Thread take-up crank	1	M
	230100017	Thread take-up crank	1	H
	BX85855009	Thread take-up crank	1	B
2-6-4	BXF8688009	Screw SM3.57-40x6L	1	
2-6-5	BX85863009	Needle bar guide	2	
2-6-6	B960006009	Screw SM3.57-40x7	1	
3	B098049074	Screw M6x10	1	
4	B908470009	Needle bar guide slide block	1	
5	BXF9977009	Needle bar	1	M
	BXF9973009	Needle bar	1	H、B
6	BXF8916909	Needle bar bush, U	1	
7	BXF9972009	Needle bar bush, D	1	M
	BXF9971009	Needle bar bush, D	1	H、B
8	B098500574	Screw M5x5	1	
9	B048500494	Screw M5x6	1	
10	S150901001	Needle DBx1 14#	1	M
	S150901002	Needle DPx5 18#	1	H
	S150901003	Needle DPx5 22#		B
11	B960557908	Screw SM3.18		

2. NEEDLE BAR AND THREAD TAKE-UP MECHANISM

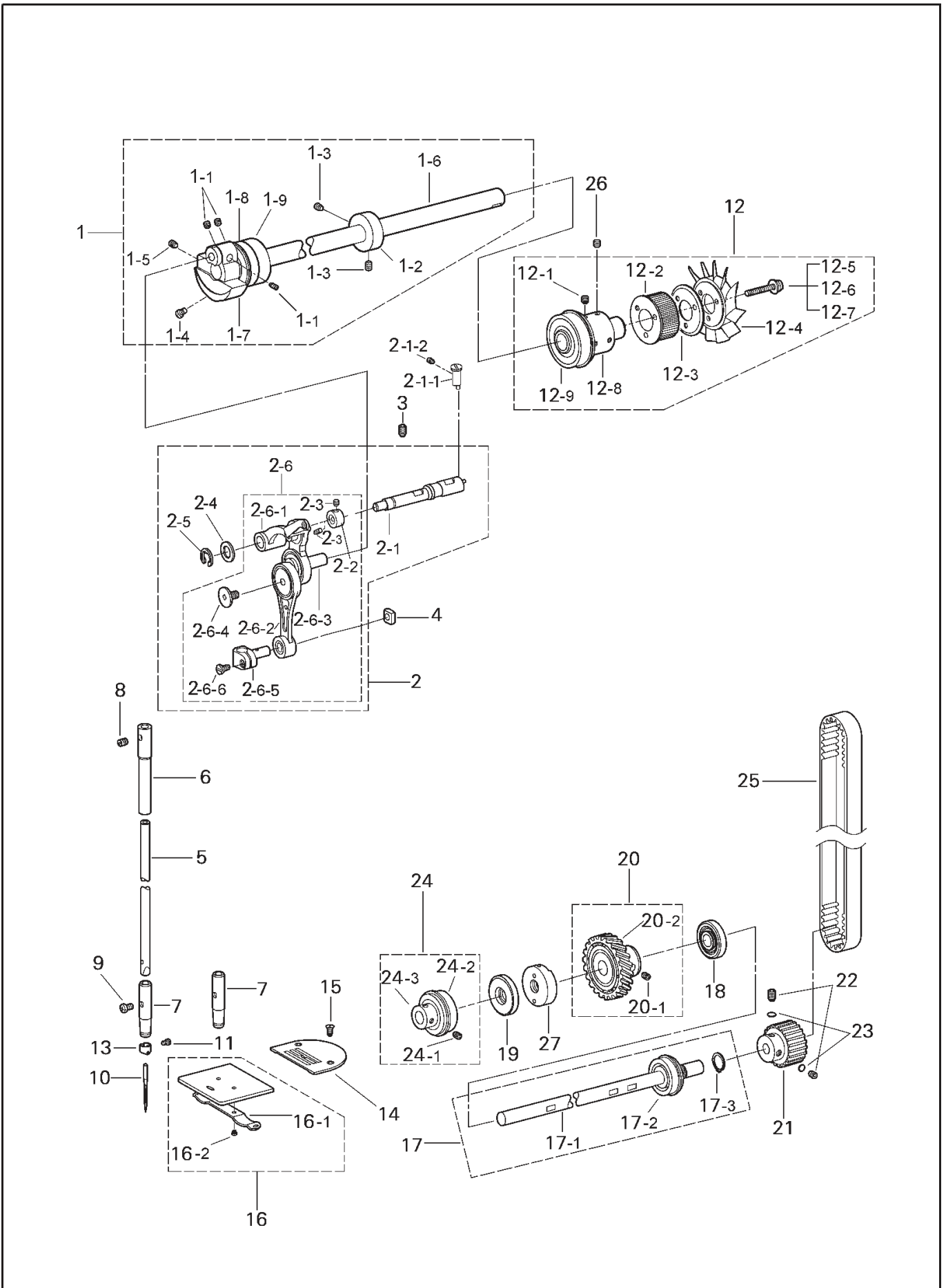

2. NEEDLE BAR AND THREAD TAKE-UP MECHANISM

No.	Ref.No.	Description	Qt	Note
12		Joint unit	1	
12-1	BX87459009	Set screw M6x6	2	
12-2	BXF8850009	Timing pulley,U	1	
12-3	BX72398009	Flange	1	
12-4	BX72397900	Fan	1	
12-5	B048607598	Screw M4x35	3	
12-6	S150602005	Spring washer 4	3	
12-7	B085060878	Washer M4	3	
12-8	BXF9969009	Power transmission	1	
12-9	S150801016	Bearing 6204 2ZNR	1	
13	B959516009	Needle bar thread guide	1	
14	153100002	Needle plate	1	M
	153100004	Needle plate	1	H
	230G20003	Needle plate	1	B
15	022100020	Screw SM4.37-40x8	2	
16	B920092959	Slide plate assy	1	
16-1	B996549059	Spring,plate	1	
16-2	B988339059	Screw SM2.38	2	
17	BXF9967009	Lower shaft assy	1	
17-1	BXF9966009	Lower shaft	1	
17-2	S150801020	Bearing 6301 2ZNR	1	
17-3	B062980968	Retaining ring C12	1	
18	BX85609900	Oil seal,NOK BC4907E	1	
19	BXF9793009	Oil seal,NOK XC0028E	1	
20	BXF9944009	Lower shaft gear assy	1	
20-1	BX87459009	Set screw M6x6	2	
20-2	BXF9943009	Gear	1	M、H
	230G30001	Gear	1	B
21	BXF8859009	Timing pulley,D	1	
22	BX87459009	Set screw M6x6	2	
23	BXF8732009	Washer 4,8	2	
24	BXF9950009	Bearing bush assy	1	
24-1	BX87459009	Set screw M6x6	2	
24-2	S150801008	Bearing 6004 2ZNR	1	
24-3	BXF9959009	Bearing bush R	1	
25	BXF8858009	Timing belt 570-3GT-15	1	
26	BX87459009	Set screw M6x6	2	
27	BXF8856909	Lower shaft bush	1	

3. PRESSER FOOT MECHANISM

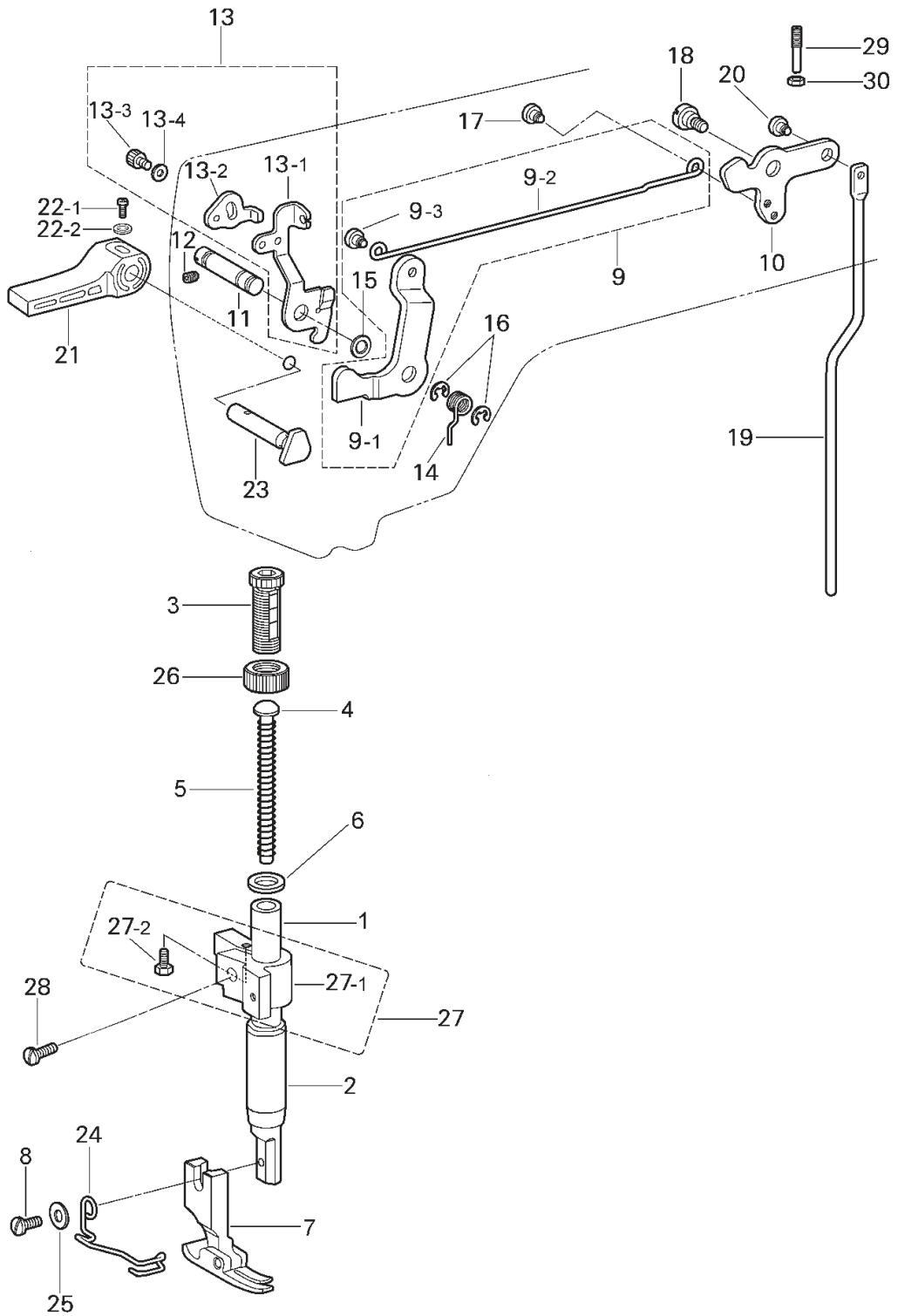

3. PRESSER FOOT MECHANISM

No.	Ref.No.	Description	Qt	Note
1	BXF9939009	Presser bar	1	
2	BXF3868009	Presser bar bush	1	
3	BXF9936009	Presser adjusting screw M14	1	
4	B969802089	Spring guide	1	
5	230100021	Presser bar spring	1	M
	BX97549909	Presser bar spring	1	H、B
6	B960603009	Washer	1	
7	02276	Presser foot assy	1	M
	153720000	Presser foot assy	1	H、B
8	022700015	Screw SM3.57-40x11	1	
9	BXF9934009	Presser bar lifter lever assy	1	
9-1	BXF9933009	Presser bar lifter lever	1	
9-2	BXF9932009	Nee lifter connecting rod	1	
9-3	BXF9931009	Shoulder screw M5	1	
10	BXF7120009	Knee lifter lever	1	
11	BXF9929009	Presser bar lifter lever shaft	1	
12	B098500574	Set screw M5x5	1	
13	BXF9928009	Tension release plate assy	1	
13-1	BXF9927009	Tension release plate	1	
13-2	BXF9926009	T-release selection plate	1	
13-3	B092600578	Bolt M4x5	1	
13-4	217100049	Washer M4	1	
14	BXF9924009	P-bar lifter lever spring	1	
15	BX03750009	Washer	1	
16	B062050768	Retaining ring E5	2	
17	BXF9931009	Shoulder screw M5	1	
18	BXF8945009	Shoulder screw M6	1	
19	BXF9910009	Knee lifter bar	1	
20	BXF9931009	Screw M5	1	
21	BX79004089	Lifting lever	1	
22-1	B048759894	Screw M3.5x12	1	
22-2	S150607008	Washer 4	1	
23	260140013	Presser bar lifter crank	1	
24	057700002	Finger guard	1	
25	B085750978	Washer S3.5	1	
26	BXF9935009	Adjust screw nut M14	1	
27		Presser bar guide bracket assy	1	
27-1	BXF2006009	Presser bar guide bracket	1	
27-2	BXF9917009	Bolt M3x7.5	1	
28	230100020	Screw M4x12	1	
29	BXF9921009	Adjust screw M6	1	
30	B089040704	Nut M6	1	

4. FEED MECHANISM

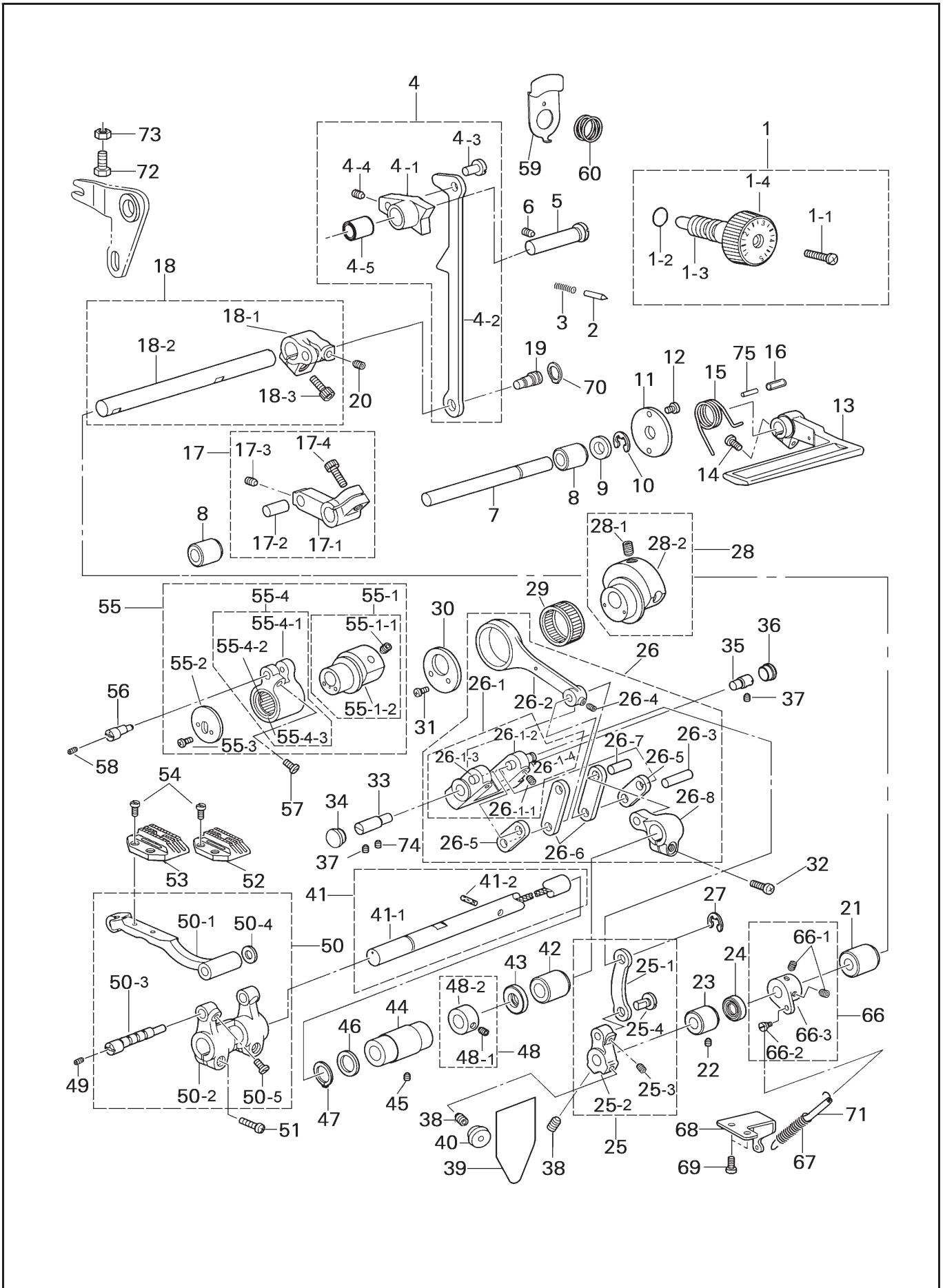

4. FEED MECHANISM

No.	Ref.No.	Description	Qt	Note
1		Stitch length dial assy	1	
1-1	BXF6616009	Screw SM4.76	1	
1-2	124510003	O Ring	1	
1-3	217N00021	Feed regulating supporter	1	
1-4	230100010	Needle pitch knob 5mm	1	M、H
	230G40004	Needle pitch knob 7mm	1	B
2	036500012	Positioning pin	1	
3	022500009	Spring	1	
4		Feed regulator assy	1	
4-1	217N00023	Feed regulator	1	M、H
	230G40002	Feed regulator	1	B
4-2	BXF9806009	F- regulator connecting rod	1	
4-3	217100043	Connecting stud	1	
4-4	B098500574	Set screw 5x5	1	
4-5	B968736900	Bush L=20	1	
5	BXF3475009	Feed regulator shaft	1	
6	B098049074	Set Screw M6x5	2	
7	BXF9804009	Reverse sewing shaft	1	
8	BX85641900	Bush L=12	2	
9	B085900978	Washer S10	1	
10	B062020768	Retaining ring E8	1	
11	BXF9803009	Spacer	1	
12	B048500294	Screw M5x8	2	
13	BXF3789009	Reverse lever	1	
14	B048509694	Screw M5x14	1	
15	BXF9801009	Reverse lever spring	1	
16	B957978000	Nylon tube L=13.5	1	
17		Handle shaft arm assy	1	
17-1	BXF9899009	Handle shaft arm	1	
17-2	B954152089	Feed rock arm shaft pin	1	
17-3	B098500574	Set screw M5x5	1	
17-4	B092509474	Bolt M5x16	1	
18		Feed regulator shaft assy	1	
18-1	BXF8250909	Feed regulator shaft arm	1	
18-2	BXF9896009	Feed regulator shaft	1	
18-3	S150299025	Bolt M6x16	1	
19	BXF8259009	Eccentric pin	1	
20	B098500574	Set screw M5x5	1	
21	BXF9895009	Feed regulator shaft bush R	1	
22	B098040574	Set screw M6x5	1	
23	BXF9894009	Feed regulator shaft bush L	1	
24	BXF9841009	Oil seal AC0371E	1	
25	BXF9893009	Connecting rod S assy	1	
25-1	BX79211959	F-regulator connecting rod	1	
25-2	BXF9892009	Feed regulator shaft joint	1	
25-3	B098500574	Set screw M5x5	1	
25-4	217100043	Connect pin	1	
26		Feed regulator unit	1	
26-1		Feed regulator assy	1	
26-1-1	B098500574	Set screw M5x5	2	
26-1-2	BXF3785009	Feed regulator	1	
26-1-3	B954159089	Crank short connecting pin	1	
26-1-4	217100010	Crank length connecting pin	1	
26-2	BXF9887009	Level feed connecting rod	1	
26-3	BXF9886009	Link shaft	1	
26-4	B098500574	Set screw M5x5	2	
26-5	BX94774009	Level feed link assy	2	
26-6	BX94772009	Feed rocker arm link assy	2	
26-7	BX58105009	F-rocker arm stud	1	
26-8	BXF9885009	Feed rock arm	1	
27	B062060768	Retaining ring E4	1	
28		Eccentric wheel unit	1	
28-1	BX85874009	Set screw M6x10	2	
28-2	BXF9846009	Eccentric wheel	1	M、H
	230G40001	Eccentric wheel	1	B
29	S150801039	Roller bearing K25x29x10	1	
30	BX85789009	Guardrail splint	1	

4. FEED MECHANISM

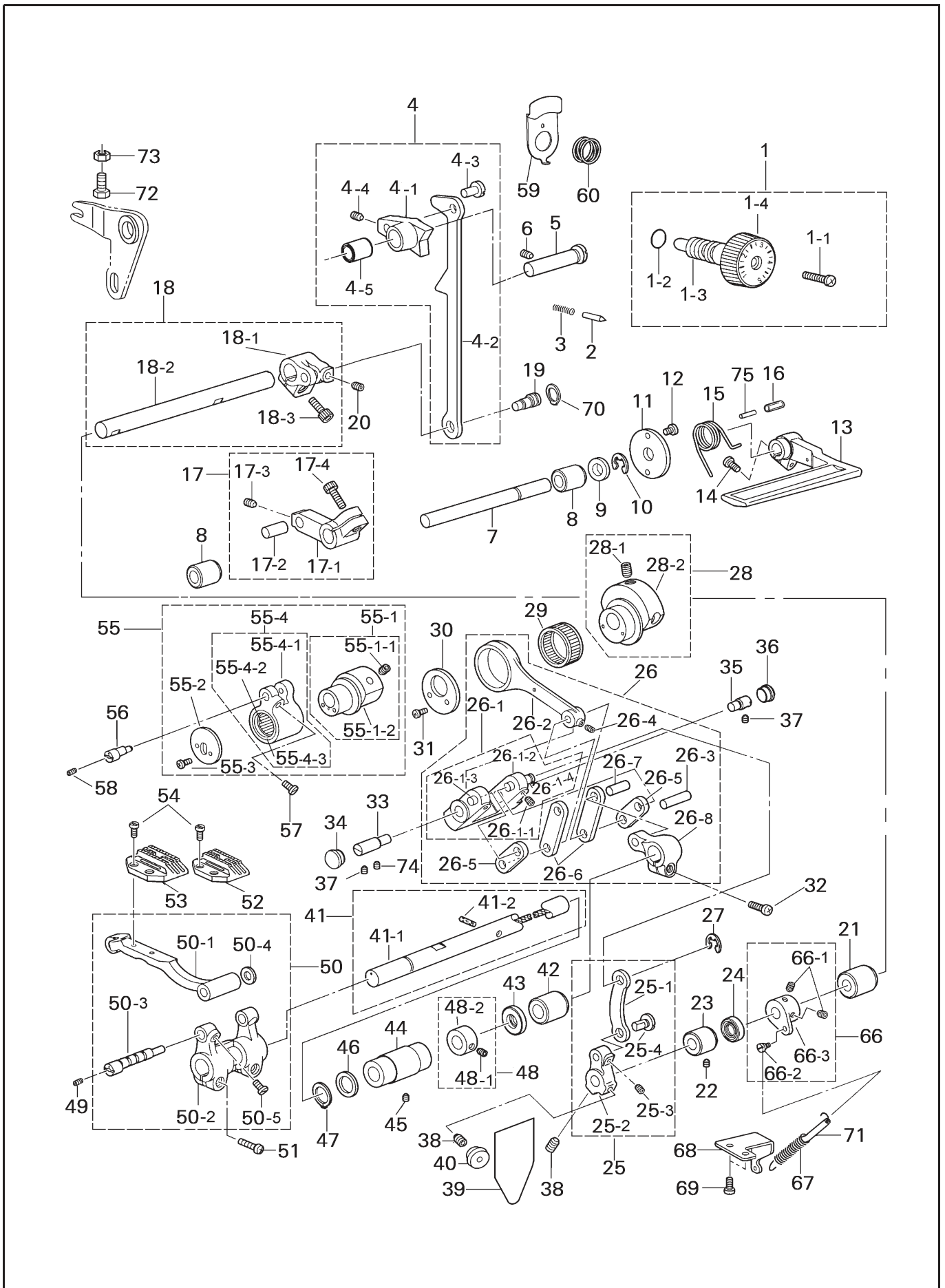

4. FEED MECHANISM

No.	Ref.No.	Description	Qt	Note
31	B048750494	Screw M3.5x6	2	
32	B048509694	Screw M5x14	1	
33	BXF9884009	Feed regulator shaft L	1	
34	B906661009	Rubber cap 15.5	1	
35	BXF9883009	Feed regulator support shaft	1	
36	BXF9882009	Rubber cap 14.5	1	
37	B098040574	Set screw M6x5	2	
38	BX87459009	Set screw M6x6	2	
39	001C10010	Rubber cap label	1	
	001C10011	Rubber cap label	1	
40	BX76758909	Rubber cap 13.5	1	
41		Feed rock shaft assy	1	
41-1	BXF9879009	Feed rock shaft	1	
41-2	BXF8948009	Felt	1	
42	BXF9874009	Feed shaft bush R	1	
43	BXF9873009	Oil seal XC0029E	1	
44	BXF9877009	Feed shaft bush L	1	
45	B098040574	Set screw M6x5	1	
46	B954867089	Thrust ring 2x15x22ST	1	
47	B062950968	Retaining ring external C15	1	
48		Set screw collar	1	
48-1	BX87459009	Set screw M6x6	2	
48-2	BXF9875009	Tighten ring	1	
49	B096700678	Set screw M3x4	1	
50		Feed bar assy	1	
50-1	BXF9871809	Feed bar	1	
50-2	BXF3770009	Feed lifting rock shaft crank	1	
50-3	217100016	Feed bar shaft	1	
50-4	B952388089	Washer 4.2	1	
50-5	BXF9868009	Set screw M5x7	1	
51	BXF3853009	Set screw M5x14	2	
52	BXF8765009	Feed dog	1	M
53	153600001	Feed dog	1	H
	022610003	Feed dog	1	B
54	022610004	Screw SM3.18-44x6	2	
55		F-lifting eccentric wheel assy	1	M
		F-lifting eccentric wheel assy	1	H、B
55-1		Eccentric wheel assy	1	M
		Eccentric wheel assy	1	H、B
55-1-1	BX85874009	Set screw M6x10	2	
55-1-2	BXF9862009	Eccentric wheel	1	M
	BXF9858009	Eccentric wheel	1	H、B
55-2	BX85771909	Feed bracket arm presser	1	
55-3	S150299030	Screw M3x6	2	
55-4		Crank assy	1	
55-4-1	217101001	Feed lifting rock shaft crank	1	
55-4-2	S150801034	Needle bearing K20x24x13	1	
55-4-3	217101002	retaining ring	2	
56	217100017	Feed bar shaft	1	
57	BXF9868009	Set screw M5x7	1	
58	B096700678	Set screw M3x4	1	
59	230100023	Stitch button	1	
60	036500011	Spring	1	
66		Spring hook arm assy	1	
66-1	BX87459009	Screw M6x6	2	
66-2	BX85683909	Shoulder screw M4	1	
66-3	BXF8818009	Spring setting plate	1	
67	BXF8816009	Spring	1	
68	BXF8817009	Spring pull plate	1	
69	B048500294	Set screw M5x8	2	
70	B062900968	Retaining ring C10	1	
71	BXF7996009	Vinyl tube 3x5 L=70	1	
72	BXF8763009	Bolt M5x16	1	
73	B089500794	Nut M5	1	
74	S150299016	Screw M6x8	1	
75	B960047009	Pin	2	

5. QUICK REVERSE MECHANISM

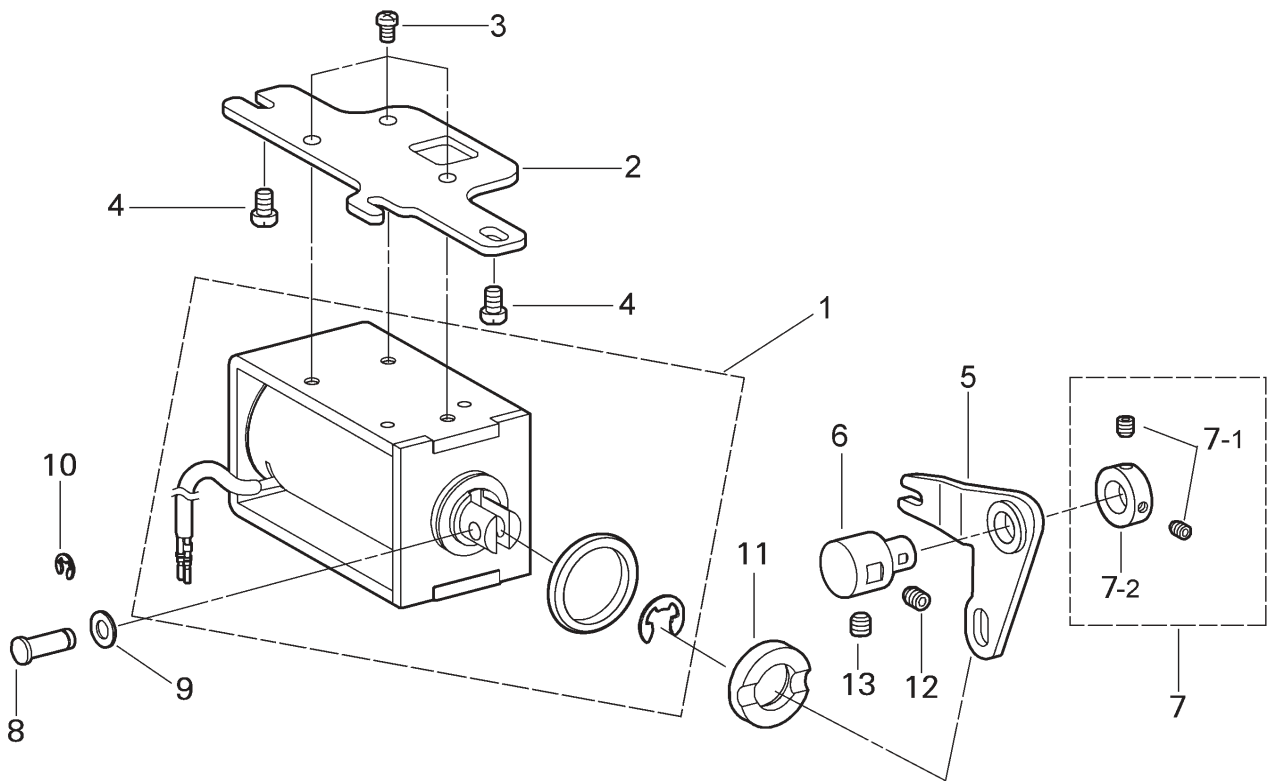

5. QUICK REVERSE MECHANISM

No.	Ref.No.	Description	Qt	Note
1	BXF9711909	Backstitch solenoid assy	1	
2	BXF9852009	Solenoid base	1	
3	B048500294	Screw M5x8	3	
4	B048049094	Screw M6x10	2	
5	BXF8258009	Solenoid lever	1	
6	BXF8266009	Solenoid lever shaft	1	
7		Set collar assy	1	
7-1	B098500574	Set screw M5x5	2	
7-2	217100006	Set collar	1	
8	BXF8118009	Connect pin	1	
9	217100045	Washer 6,5	1	
10	S150617001	Retaining ring C6	1	
11	BXF8824009	Rubber cushion	1	
12	B098040574	Set screw M6x5	1	
13	B098500574	Set screw M5x5	1	

6. TENSION RELEASE MECHANISM

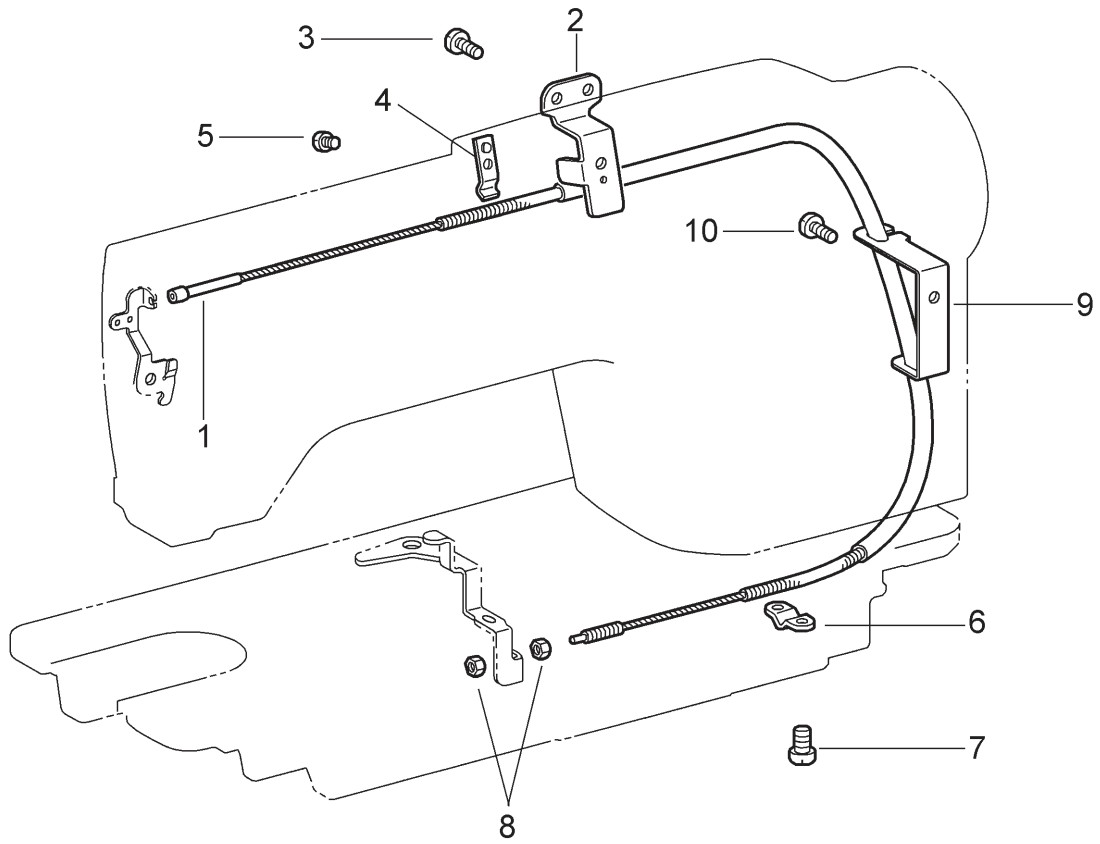

6. TENSION RELEASE MECHANISM

No.	Ref.No.	Description	Qt	Note
1	BXF9739809	Tension release steel wire	1	
2	217200002	Wire holder	1	
3	B048500294	Screw M5x8	2	
4	BXF9737009	Wire holder U	1	
5	B040600594	Screw M5x4	1	
6	B956403909	Wire holder D	1	
7	B040600294	Screw M4x8	2	
8	B990949006	Nut SM4.76	2	
9	217200003	Wire cord holder	1	
10	B048500294	Screw M5x8	1	

7. ROTARY HOOK MECHANISM

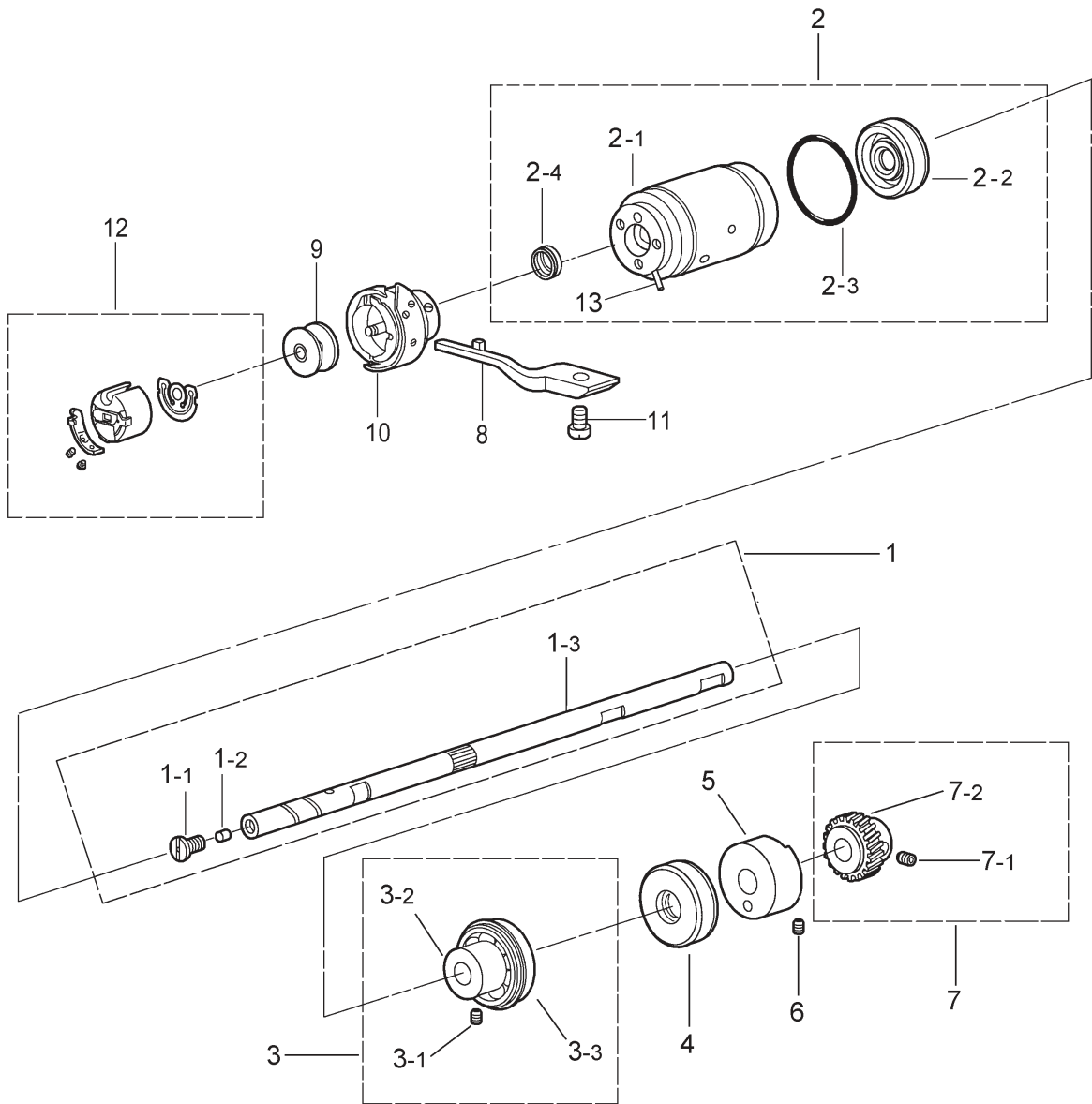

7.ROTARY HOOK MECHANISM

No.	Ref.No.	Description	Qt	Note
1		Rotary hook shaft assy	1	
1-1	BXF3962009	Screw M5-0.8	1	
1-2	217100036	Oil stopper	1	
1-3	BXF3848909	Rotary hook shaft	1	M、H
	230G30004	Rotary hook shaft	1	B
2		Pump bush unit	1	
2-1	BXF3846009	Pump bush	1	M、H
	230G30003	Pump bush	1	B
2-2	BX85608000	Oil seal	1	
2-3	B029085230	O ring S25	1	
2-4	BXF3780009	Oil seal	1	
3		Bearing bush assy	1	
3-1	BX87459009	Set screw M6x6	2	
3-2	BXF9828009	Bearing bush	1	
3-3	S150801023	Bearing NSK 6901 2ZNR	1	
4	BXF9826009	Oil seal	1	
5	BXF9825009	Rotary hook shaft gear bush	1	
6	B098040574	Set screw M6x5	1	
7		Rotary hook shaft gear assy	1	
7-1	BX87459009	Set screw M6x6	2	
7-2	BXF9823009	Rotary hook shaft gear		M、H
	230G30002	Rotary hook shaft gear		B
8	BX08408089	Hook stopper	1	M
	B951786089	Hook stopper	1	H
	078400003	Hook stopper	1	B
9	036400006	Bobbin	1	M
	048400003	Bobbin	1	H
	078400005	Bobbin	1	B
10	BXF3424008	Rotary hook	1	M
	217C00001	Rotary hook	1	H
	12041	Rotary hook	1	B
11	217100030	Screw M4x12	1	M、H
	022400015	Screw	1	B
12	03642	Bobbin case assy	1	M、H
	12042	Bobbin case assy	1	B
13	BXF3249009	Pin	1	

8.LUBRICATION MECHANISM

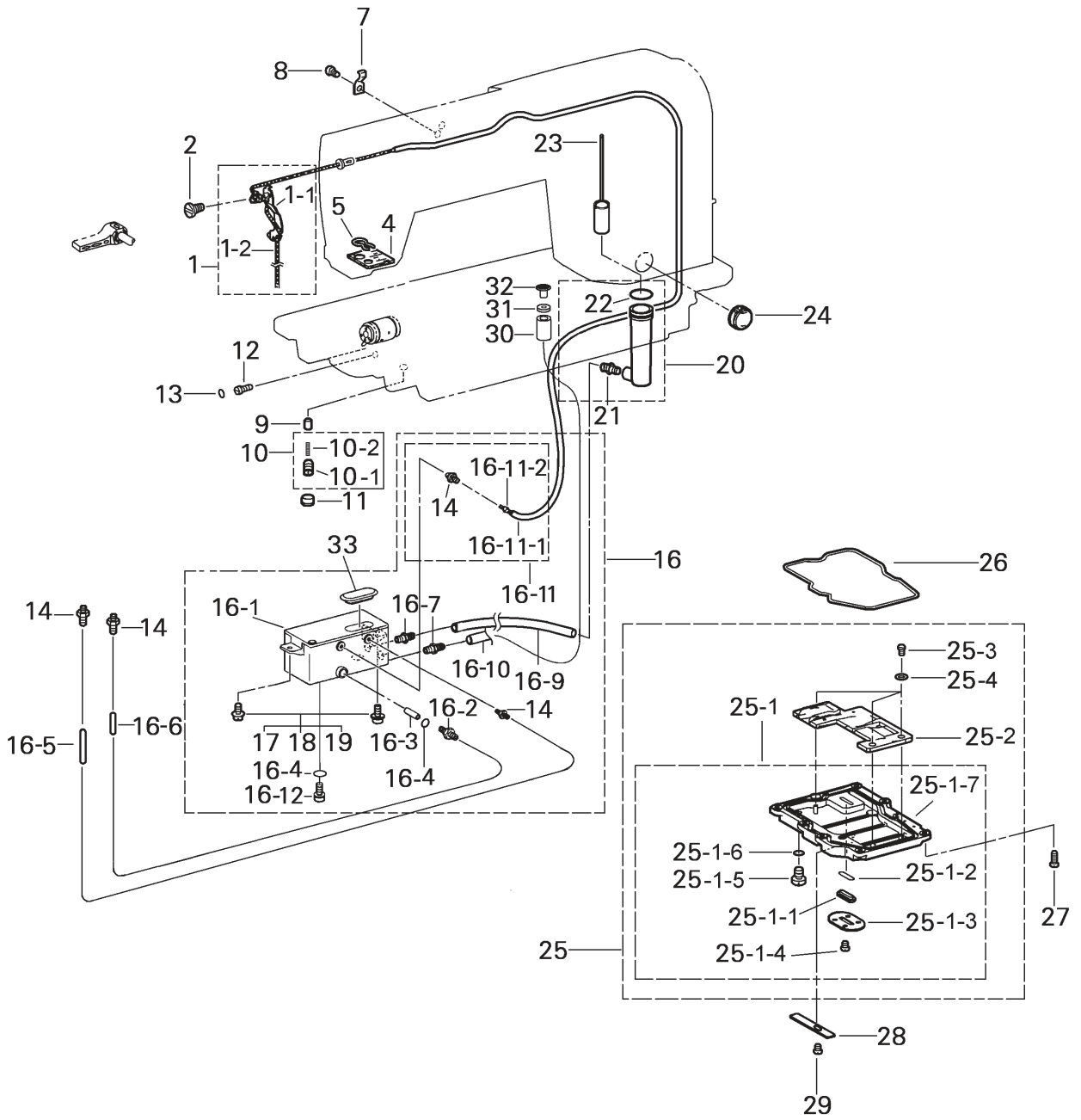

8. LUBRICATION MECHANISM

No.	Ref.No.	Description	Qt	Note
1		Wick holder assy	1	
1-1	230100018	Wick holder	1	
1-2		Wick	1	
2	BXF9868009	Screw M5x7	1	
4	BX72341000	Felt	1	
5	B965373089	Felt support	1	
7	BXF9815009	Cord holder T2	1	
8	B048500294	Screw M5x8	1	
9	036400015	Plunger	1	
10		Pump cap screw assy	1	
10-1	BX85720609	Screw	1	
10-2	B966234009	Spring compression	1	
11	B906289009	Rubber cap 10.5	1	
12	BX85729009	Adjusting screw	1	
13	B029006230	O ring S4	1	
14	BX85728009	Oil feeding pipe	4	
16	230121000	Oil tank set	1	
16-1	230121100	Oil tank assy	1	
16-2	230121002	Oil feeding pipe M8	1	
16-3	230100014	FeltΦ6x15	1	
16-4	B029002030	O ring P8	2	
16-5	BXF9700009	Vinyl tube 3x5 L=140	1	
16-6	BXF9700009	Vinyl tube 3x5 L=100	1	
16-7	BXF7060009	Oil feeding pipe	2	
16-9	BXF9700009	Vinyl tube 6x8 L=190	1	
16-10	BXF7940009	Vinyl tube 6x8 L=250	1	
16-11	BXF8767009	Vitta assy	1	
16-11-1	BXF9706009	Vinyl tube 3x5 L=900	1	
16-11-2	W180103099	Nylon wick	1	
16-12	BXF9707009	Screw M8	1	
17	B048509894	Screw M5x12	2	
18	B082050864	Spring washer 2-5	2	
19	B085050874	Washer 5	2	

8.LUBRICATION MECHANISM

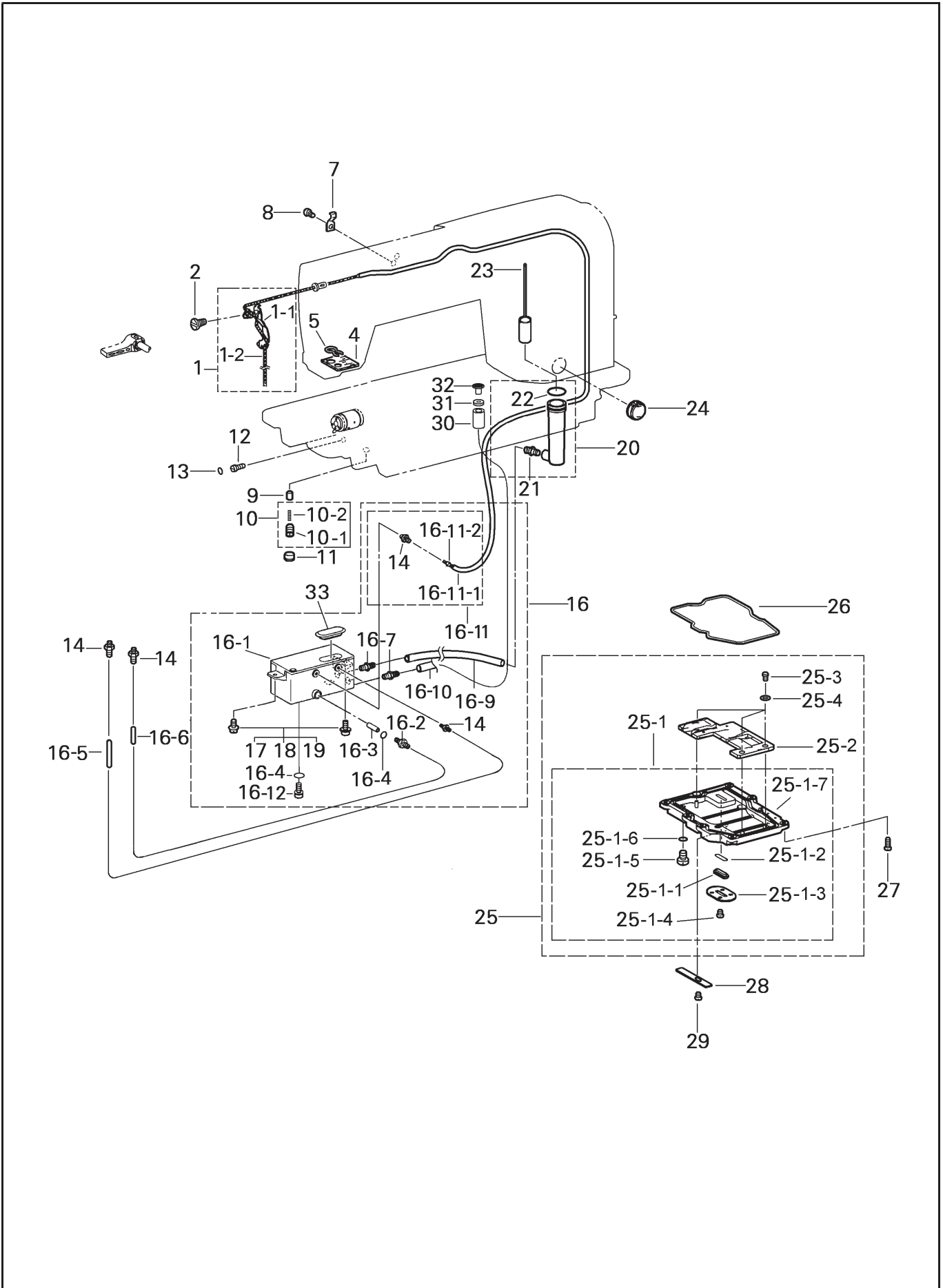

8. LUBRICATION MECHANISM

No.	Ref.No.	Description	Qt	Note
20		Sub tank assy	1	
21	230120001	Oil feeding pipe	1	
22	B029088230	O ring S22	1	
23	230122000	Float assy	1	
24	BX63501009	Oil gauge window	1	
25		Bed bottom cover unit	1	
25-1		Bed bottom cover assy	1	
25-1-1	BX59838000	Oil window B-cover	1	
25-1-2	B029095230	O ring S15	1	
25-1-3	BXF9797009	Window cover	1	
25-1-4	B048500494	Screw M5x6	4	
25-1-5	BXF9707009	Screw M8	1	
25-1-6	B029002030	O ring P8	1	
25-1-7	217100014	Bed bottom cover	1	
25-2	BXF9795709	Bottom cover felt	1	
25-3	B048600494	Screw M4x6	3	
25-4	S150610003	Washer plain L4	3	
26	BXF9796009	Bottom cover packing	1	
27	B048509894	Screw M5x12	9	
28	BXF9794009	Cord holder plate	1	
29	B048500494	Screw M5x6	1	
30	230121003	Oil feeding pocket	1	
31	230121004	Rubber tube	1	
32	230121005	Rubber cap	1	
33	230121001			

9. THREADING MECHANISM

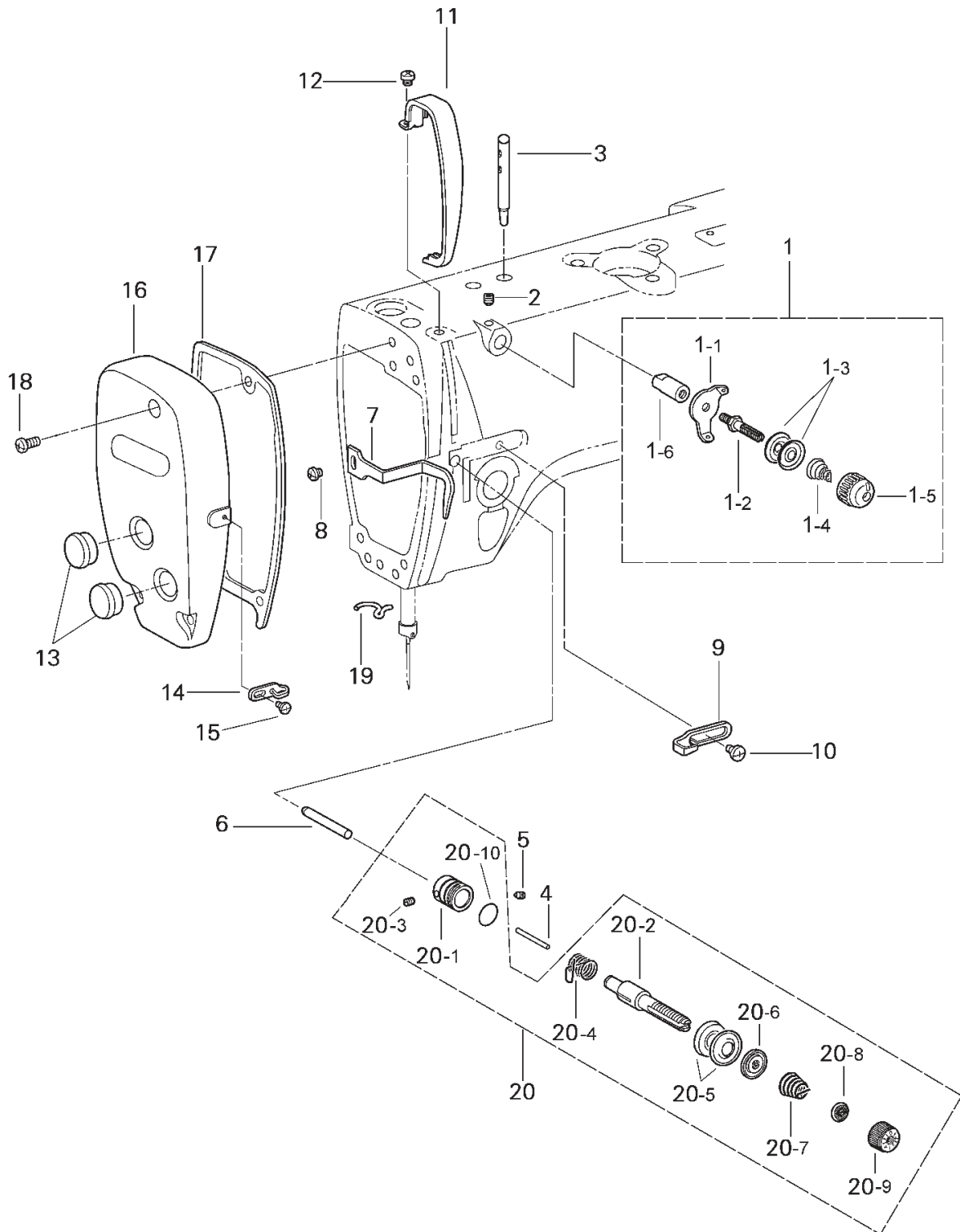

9. THREADING MECHANISM

No.	Ref.No.	Description	Qt	Note
1	BXF8758909	Pre-tension assy B	1	
1-1	BXF8748009	Thread guide	1	
1-2	BX65547009	Thread guide tension stud	1	
1-3	B966506009	Thread guide disc	2	
1-4	BXF8752909	Pre-tension spring	1	
1-5	BXF4943009	Thread tension nut	1	
1-6	BXF8747009	Pre-tension base	1	
2	B098500574	Set screw M5x5	1	
3	BXF9751009	Spool pin	1	
4	BX09691000	Tension release pin	1	
5	BXF9881909	Set screw M6x6	1	
6	BXF9767009	Tension release stud	1	
7	BXF8693009	Thread guide P-bar bracket	1	
8	B048600294	Screw M4x8	1	
9	BXF9765009	Arm thread guide R	1	M、 H
	230G20002	Arm thread guide R	1	B
10	B040500494	Screw M5x6	1	
11	001100005	Thread take-up lever cover	1	M、 H
	230G20001	Thread take-up lever cover	1	B
12	B048500494	Screw M5x6	1	
13	230100019	Rubber cap 15.5	2	
14	BXF3839009	Face plate thread guide	1	M、 H
	078130001	Face plate thread guide	1	B
15	B040750494	Screw M3.5x6	1	
16	230100005	Faceplate	1	
17	217100018	Face plate packing	3	
18	B048509694	Screw M5x14	1	
19	B900537009	Thread guide D	1	M
	B962109009	Thread guide D	1	H、 B
20	BXF3837009	Thread tension bracket assy	1	M
	BX55455809	Thread tension bracket assy	1	H、 B
20-1	BX60172009	Thread tension bracket	1	
20-2	B994188009	Tension stud	1	
20-3	B900608006	Set screw SM3.57	1	
20-4	BX08480809	Thread take-up spring	1	
20-5	B965664009	Tension disc	2	
20-6	B951205009	Tension disc presser	1	
20-7	BXF3835009	Tension spring	1	M
	BX06478909	Tension spring	1	H、 B
20-8	BX98669009	Washer	1	
20-9	BX79078009	Tension nut	1	
20-10	B996816009	O ring	1	

10. BOBBIN WINDER MECHANISM

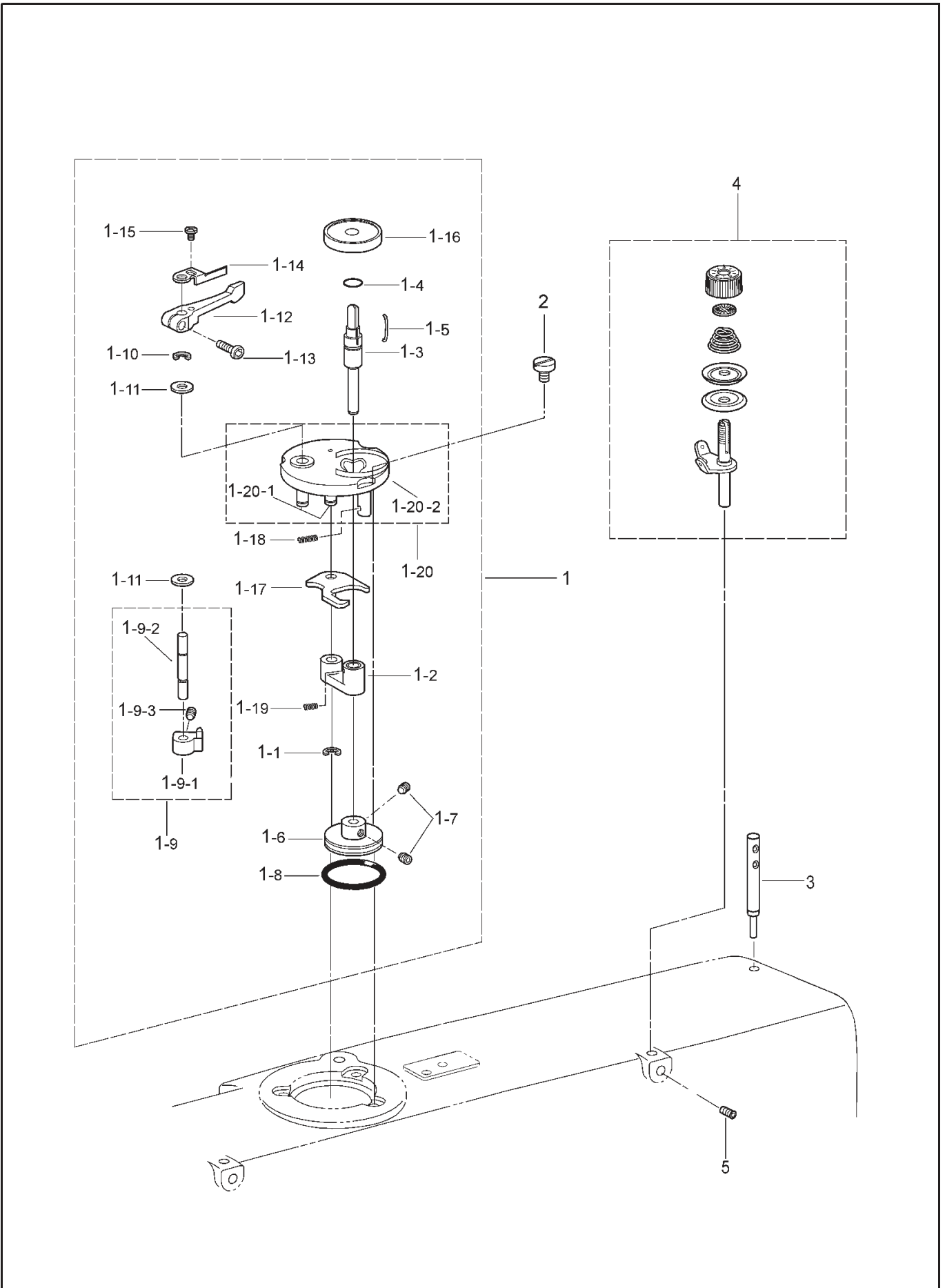

10. BOBBIN WINDER MECHANISM

No.	Ref.No.	Description	Qt	Note
1	BXF9139909	Bobbin winder unit	1	
1-1	B062060768	Retaining ting E4	1	
1-2	BXF9135009	B-winder shaft support assy	1	
1-3	BXF9132009	Bobbin winder shaft	1	
1-4	217102002	O ring	1	
1-5	217102001	Bobbin fixed spring	1	
1-6	BXF9120009	Bobbin winder wheel	1	
1-7	S150212024	Set screw M4x6	2	
1-8	BX85321000	Rubber ring	1	
1-9	BXF9129909	Bobbin presser cam assy	1	
1-9-1	BXF9128909	Bobbin presser cam	1	
1-9-2	BXF9127009	Bobbin winder arm shaft	1	
1-9-3	S150224026	Set screw M5x5	1	
1-10	B062060768	Retaining ring E4	1	
1-11	B085040974	Washer plain S6	2	
1-12	217100042	Bobbin presser arm	1	
1-13	S150237044	Screw M4x12	1	
1-14	142A11004	Thread cutter	1	
1-15	S150217018	Screw M4x5	1	
1-16	217100033	Bobbin support	1	
1-17	BXF9121009	Bobbin winder lever	1	
1-18	BXF9110909	Spring	1	
1-19	BXF9119009	Bobbin winder base spring	1	
1-20	BXF9138009	Bobbin winder support assy	1	
1-20-1	BXF9136009	Bobbin winder support shaft	1	
1-20-2	BXF9137009	Bobbin winder support	1	
2	BXF9118909	Bobbin winder fixed screw	3	
3	BXF9751009	Spool pin	1	
4	BXF9116009	Bobbin winder tension assy	1	
5	B098500574	Set screw M5x5	1	

11. THREAD TRIMMER MECHANISM

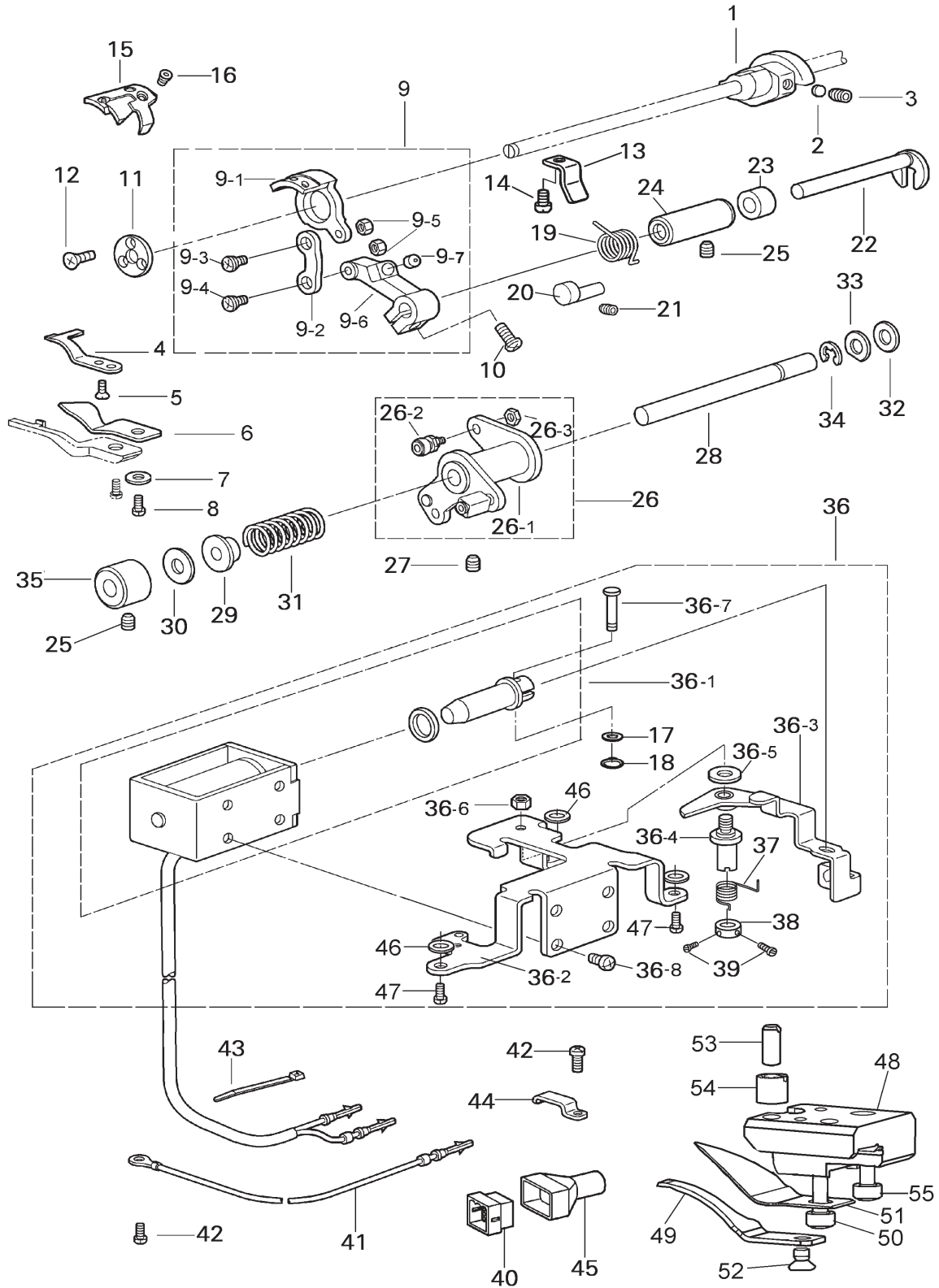

11. THREAD TRIMMER MECHANISM

No.	Ref.No.	Description	Qt	Note
1	BXF3558009	Thread trimmer cam	1	
2	165400001	Spacer 5.3	2	
3	B096339088	Set screw SM 6.35	2	
4	BX08473009	Fixed knife	1	
5	B908267006	Screw SM 3.57	1	
6	BX08467009	Lower thread finger	1	
7	B084060874	Washer M 4	1	
8	B048600494	Screw M4x6	1	
9		Thread trimmer holder assy	1	
9-1	BXF3827009	Holder M-knife	1	M、H
	230G71001	Holder M-knife	1	B
9-2	BX85684009	Thread trimmer connecting rod	1	
9-3	217100046	Shoulder screw M4	1	
9-4	217100047	Shoulder screw M4	1	
9-5	B089600704	Nut M4	2	
9-6	BXF3826809	Thread trimmer lever	1	
9-7	BXF3825009	Lever stopper	1	
10	B048509694	Screw M5x14	1	
11	BXF3823009	Knife holder presser plate	1	
12	B006709094	Screw M3x10	3	
13	BXF3769909	Thread trimmer stopper base	1	M、H
	230G74001	Thread trimmer stopper base	1	B
14	B048600494	Screw M4x6	1	
15	BX08465009	Movable knife	1	M、H
	120710002	Movable knife	1	B
16	036720003	Screw SM4.37	2	
17	B085060878	Washer plain 4	1	
18	B062060968	Retaining ring C4	1	
19	230100011	Thread trimmer lever spring	1	
20	230100012	Pin	1	
21	B098500574	Screw M5x5	1	
22	BX08463089	Forked shaft	1	
23	BX08462089	Collar	1	M、H
	230G73001	Collar	1	B
24	B956529089	Forked shaft bush	1	
25	B098040574	Screw M6x5	2	
26	BXF9748009	Thread trimmer lever unit	1	
26-1	BXF9747009	Thread trimmer lever assy	1	
26-2	BXF8852009	Roller shaft C assy	1	
26-3	B905876007	Nut SM4.37	1	
27	BX87459009	Screw M6x6	1	
28	B956517889	Thread trimmer cam lever shaft	1	
29	B956516080	Collar	1	
30	BX85676000	Rubber cushion	1	
31	217100034	Spring extension	1	
32	B956514000	Cushion	1	
33	B990743009	Washer plain special E8	1	
34	B062040768	Retaining ring E6	1	
35	BXF9744009	Cam lever shaft bush	1	

11. THREAD TRIMMER MECHANISM

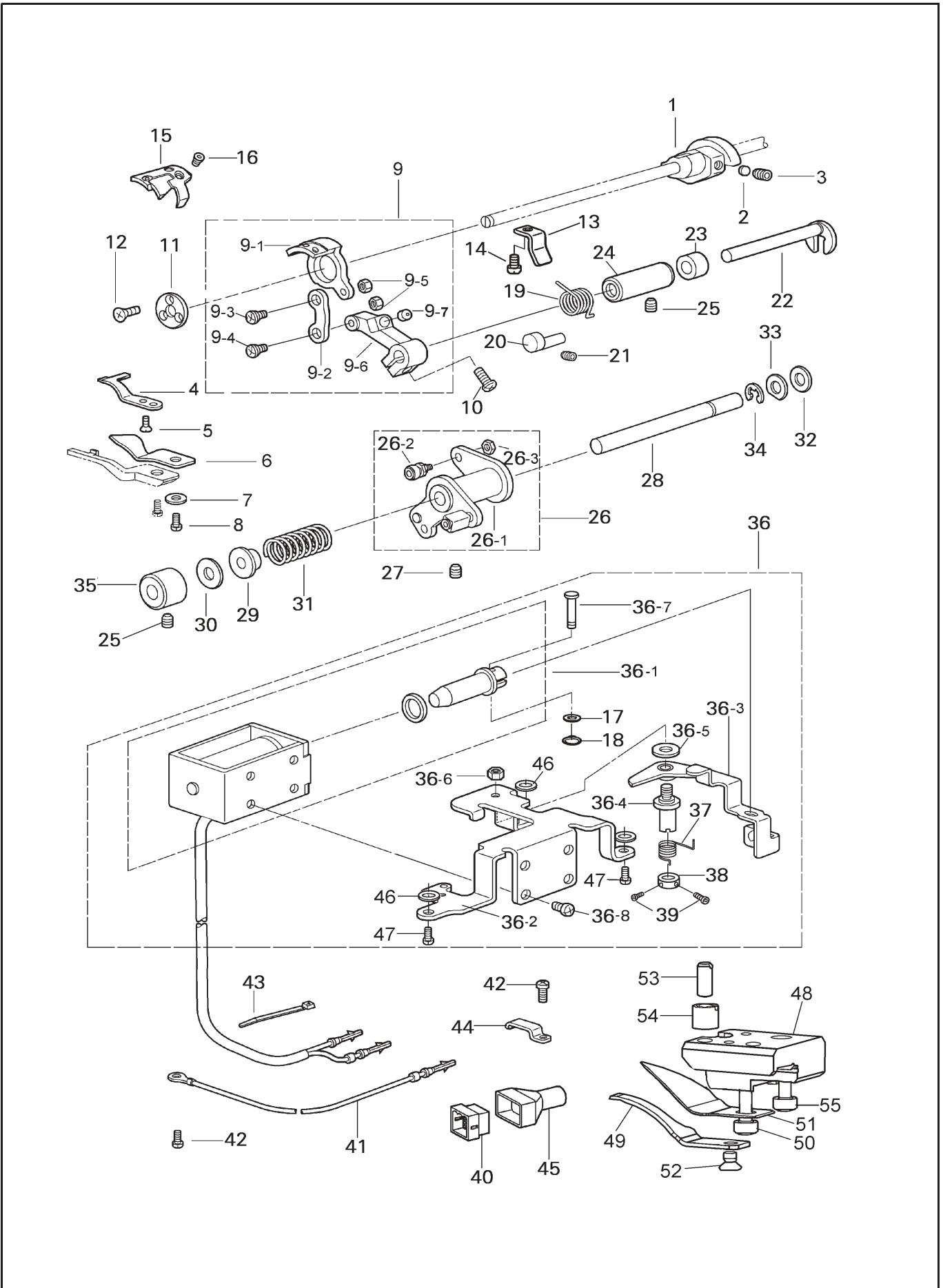

11. THREAD TRIMMER MECHANISM

No.	Ref.No.	Description	Qt	Note
36		Thread trimmer solenoid assy	1	
36-1	BXF9718009	Thread trimmer solenoid	1	
36-2	BXF9743009	Thread trimmer solenoid base	1	
36-3	BXF3212809	Solenoid lever	1	
36-4	BXF3211009	Shoulder screw M6	1	
36-5	BXF3100009	Washer	1	
36-6	B089040704	Nut M6	1	
36-7	BXF3822009	Pin	1	
36-8	B048600294	Screw M4x8	4	
37	217N00027	Cam lever spring	1	
38	036710010	Set collar	1	
39	036550008	Screw	2	
40	108500003	12-Core connector	1	
41	001C63000	Ground wire assy	1	
42	B048500294	Screw M5x8	2	
43	W060402029	Band	2	
44	230100009	Cord holder U3	1	
45	108400005	Connector cap	1	
46	230G75001	Gasket	3	B
47	B048509894	Screw M5x12	3	B
48	230G72001	Fixed knife seat	1	B
49	230G72002	Fixed knife blade	1	B
50	022130006	Screw SM3.57X40x5	1	B
51	120720001	Stop line board	1	B
52	036750004	Fastening screw	1	B
53	036750005	Adjusting screw	1	B
54	036750006	Nut	1	B
55	022200019	Screw 11/64x40x8	1	B

12. THREAD WIPER MECHANISM

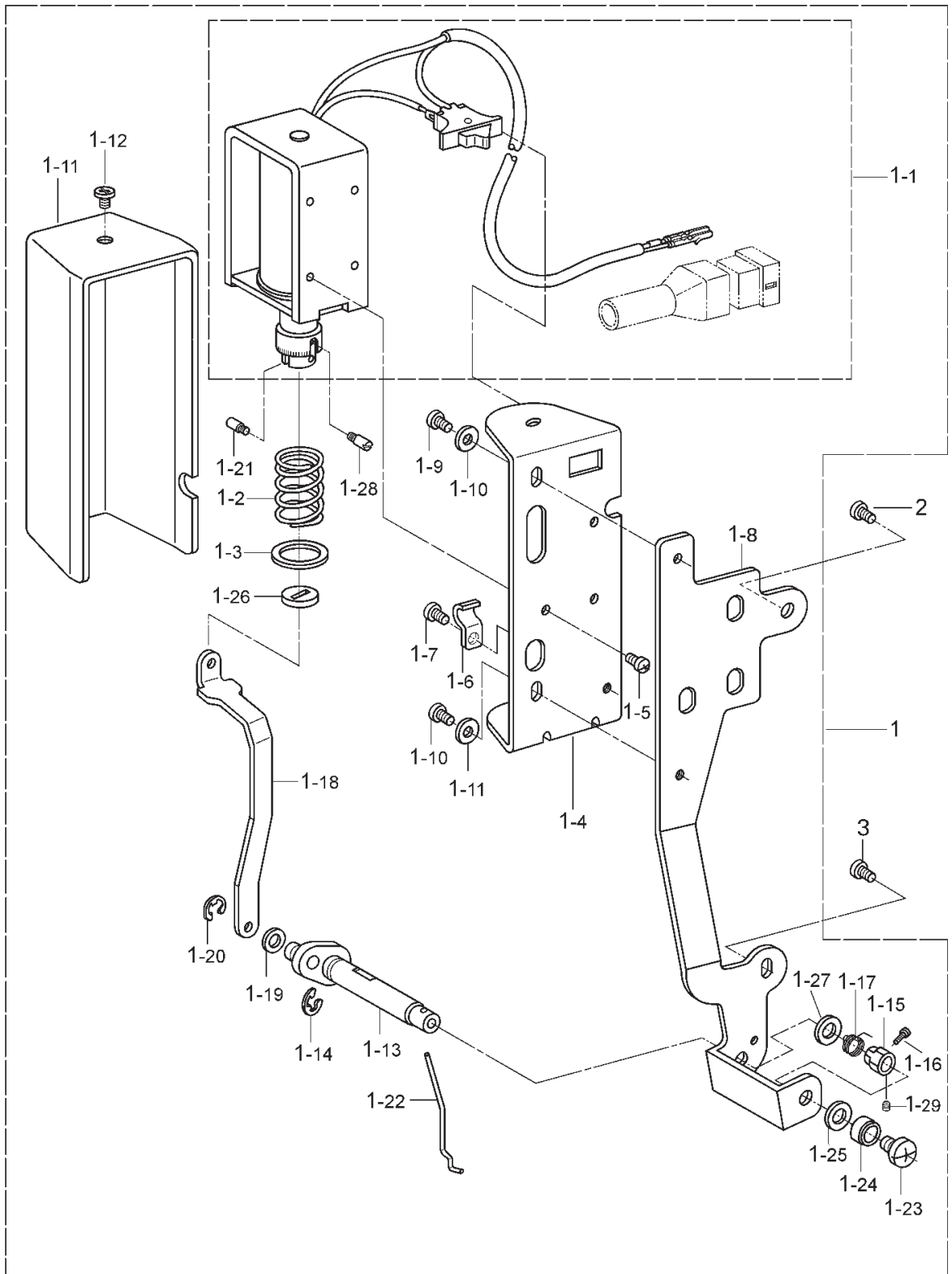

12. THREAD WIPER MECHANISM

No.	Ref.No.	Description	Qt	Note
1	BXF9736809	Thread wiper device assy	1	
1-1	BXF9714009	Thread wiper solenoid assy	1	
1-2	BX69804009	Thread wiper spring	1	
1-3	BX69805009	Washer	1	
1-4	217100028	Solenoid setting plate	1	
1-5	S150216011	Screw M3x6	3	
1-6	B960463909	Cord holder	1	
1-7	S150216011	Screw M3x6	1	
1-8	BXF9734009	Thread wiper base	1	
1-9	B048600494	Screw M4x6	2	
1-10	B084060874	Washer 4	2	
1-11	BX77490989	Solenoid cover	1	
1-12	B040600594	Screw M4x5	1	
1-13	BXF9143009	Thread wiper crank assy	1	
1-14	B062060768	Retaining ring E4	1	
1-15	BX85656089	Set screw collar	1	
1-16	BX85831009	Set screw M3.5-5	1	
1-17	BXF8823009	Spring	1	
1-18	BXF9733009	Thread wiper rod	1	
1-19	B990375088	Washer 8	1	
1-20	B062070768	Retaining ring E3	1	
1-21	BX85654089	Plunger pin	1	
1-22	BXF9732809	Thread wiper	1	
1-23	B040600594	Screw M4x5	1	
1-24	B964822089	Thread wiper stud collar	1	
1-25	BX07433089	Washer	1	
1-26	BX69803000	Spacer rubber	1	
1-27	B961013000	Silent sheet	1	
1-28	BX85654089	Plunger pin	2	
1-29	217100048	Screw M3.5-4	1	
2	B048500294	Screw M5x8	2	
3	B048509894			

13. CONTROL BOX AND MOTOR MECHANISM

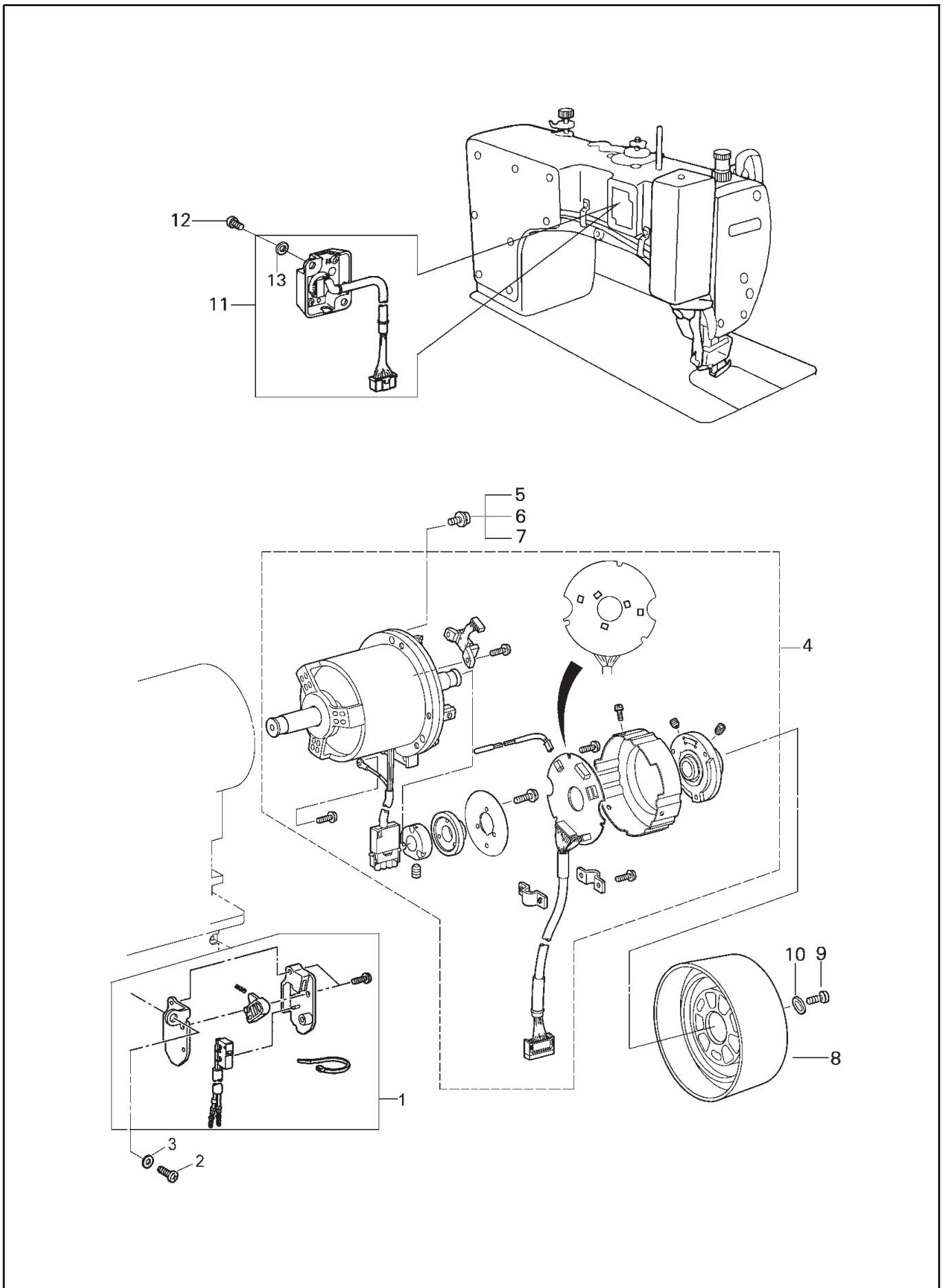

13. CONTROL BOX AND MOTOR MECHANISM

No.	Ref.No.	Description	Qt	Note
1	BXF3819909	Safety switch assy	1	
2	B048040204	Screw M6x8	1	
3	B085040974	Washer S6	1	
4	198K25200	Motor assy	1	For 8330-D
	198K12200	Motor assy	1	For HVP-70
5	S150216033	Screw M5x25	3	For 8330-D
	B048509294	Screw M5x18	3	For HVP-70
6	B082050864	Washer spring 2-5	3	
7	B084050974	Washer S5	3	
8	230100007	Pulley	1	
9	B040609094	Screw M4x10	3	
10	230100013	Pulley washer	3	
11	230210000	Detector unit	1	M
	230A10000	Detector unit	1	H
	230G20000	Detector unit	1	B For 8330-D Thread electromagnet
	230GA0001	Detector unit	1	B For 8330-D Clip solenoid
12	B048500294	Screw M5x8	1	
13	B084050974	Washer S5	1	

14. QUICK REVERSE SWITCH MECHANISM

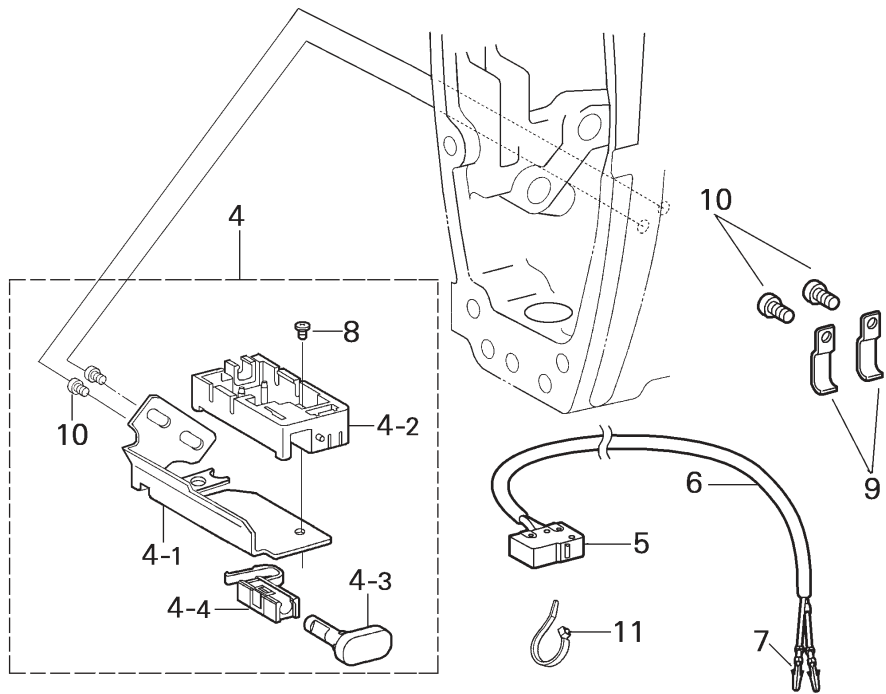
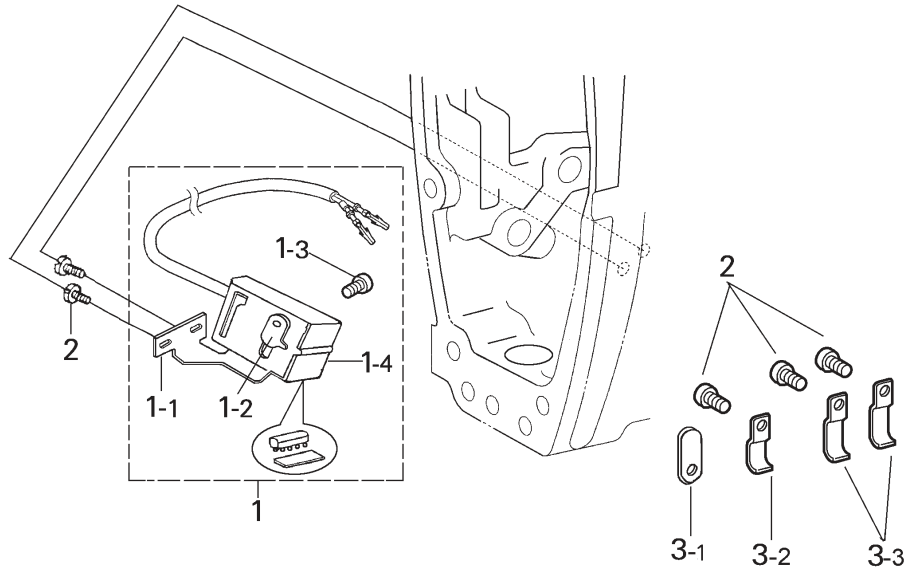

14. QUICK REVERSE SWITCH MECHANISM

No.	Ref.No.	Description	Qt	Note
1	230123000	R-actuator assy	1	For 8330-D
1-1	230123001	R-switch support	1	
1-2	230123002	Splint	1	
1-3	B048600494	Screw M4x6	1	
1-4	230123003	R-actuator assy	1	For HVP-70 or 8320-D
2	B048500294	Screw M5x8	5	
3-1	230100008	Cord holder	1	
3-2	BXF9722009	Cord holder	1	
3-3	230100009	Cord holder	2	
4	230124000	R-actuator assy	1	
4-1	230124001	R-switch support	1	
4-2	BX76829000	Reverse switch bracket	1	
4-3	BX78106000	Actuator	1	
4-4	BX78105000	switch restoration spring	1	
5	036830004	R-switch	1	
6	036832001	Down-lead	1	
7	036911002	Terminal pin, male	2	
8	S150299030	Screw M3x6	1	
9	BXF9722009	Cord holder	2	
10	B048500294	Screw M5x8	4	
11	W060042029	Band 1M	1	

15. PRESSER FOOT LIFTING SET MECHANISM

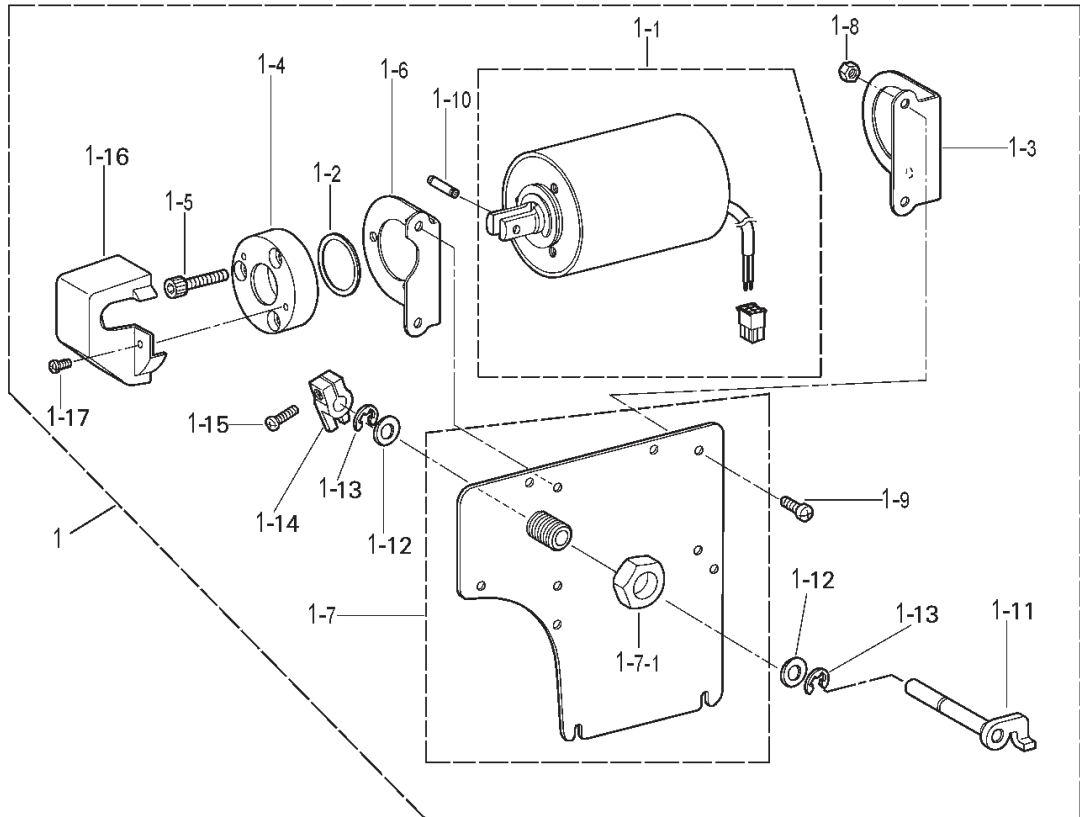

15. PRESSER FOOT LIFTING SET MECHANISM

No.	Ref.No.	Description	Qt	Note
1	BXF9169009	Solenoid P-foot lifter assy	1	
1-1	BXF9168009	P-foot lifter solenoid assy	1	
1-2	BX94485050	Rubber stopper	1	
1-3	BXF9775009	Solenoid base R	1	
1-4	BX94481959	Solenoid stopper	1	
1-5	B092349272	Bolt SM5.95x18	3	
1-6	BXF9774009	Solenoid base L	1	
1-7	BXF9150009	Rear plate	1	
1-7-1	BXF8814009	Nut M20	1	
1-8	S150503005	Nut M6	4	
1-9	S150106003	Bolt M6x12	4	
1-10	BX94470059	Pin	1	
1-11	BXF9778009	Knee lifter shaft	1	
1-12	BX80754009	Washer 10	2	
1-13	B062020768	Retaining ring E8	2	
1-14	BXF9772009	Presser foot lifter arm	1	
1-15	B048509694	Screw M5x14	1	
1-16	BX94467001	Cover	1	
1-17	B048430498	Screw SM3.57-40x6	2	

16. ACCESSORIES

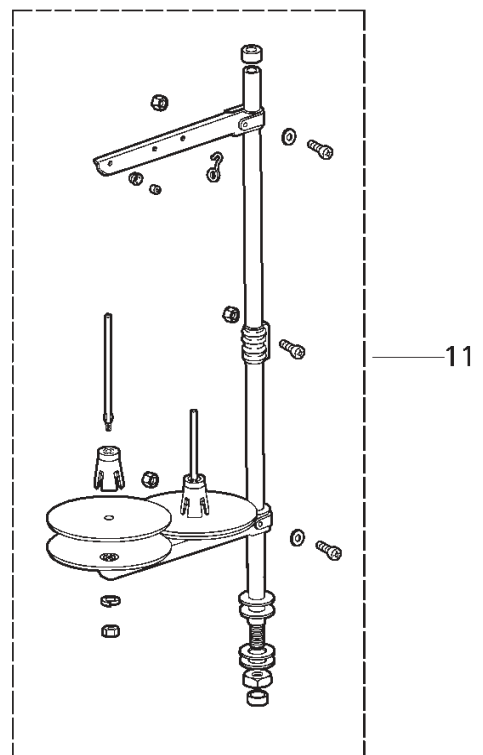
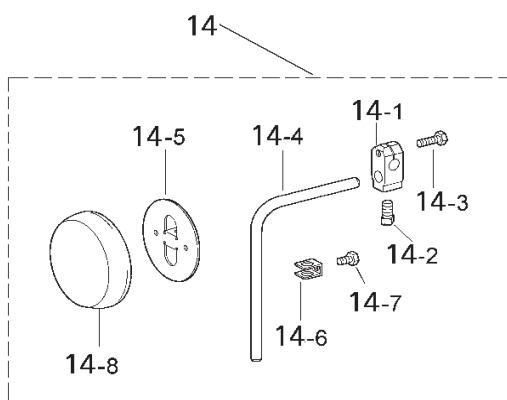
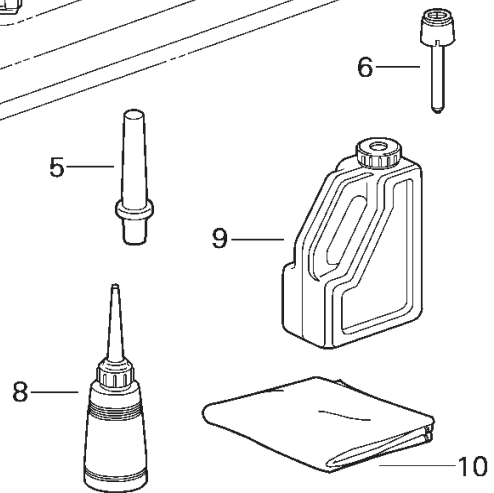
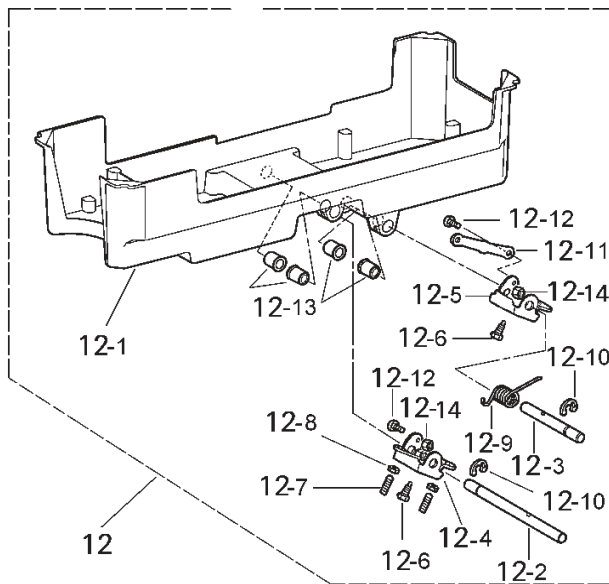
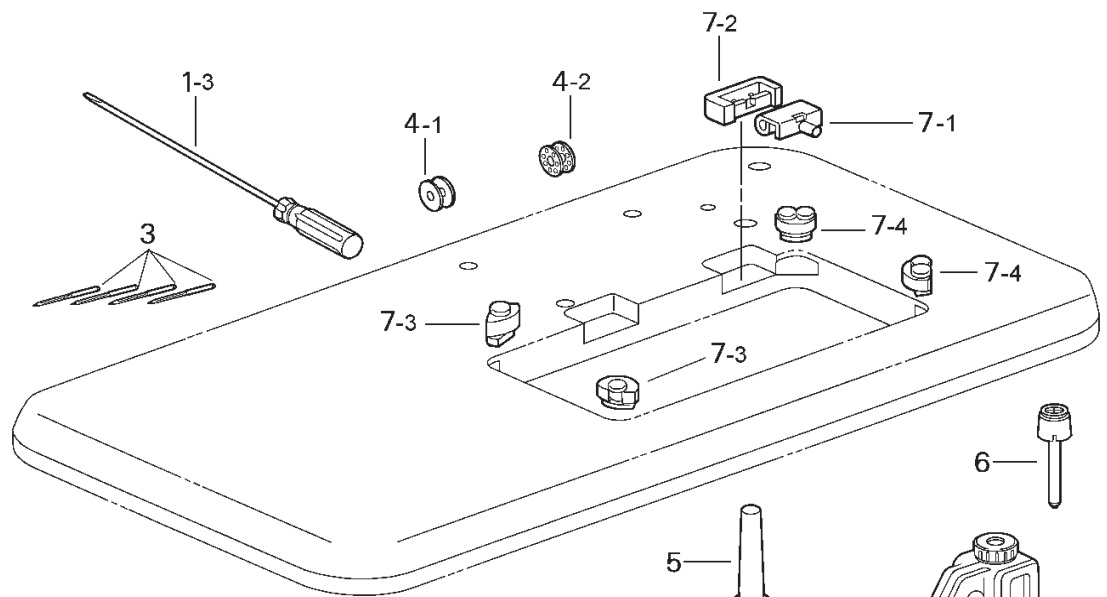

16.ACCESSORIES

No.	Ref.No.	Description	Qt	Note
1-3	W050102050	Screw-driver	1	
3	S150901001	Needle	4	M
	S150901002	Needle	4	H
	S150901003	Needle	4	B
4-1	036400006	Bobbin	3	M
4-2	048400003	Bobbin	3	H
	078400005	Bobbin	3	B
5	BX04055001	Head rest	1	
6	BX01476080	Knee lifter complying bar	1	
7-1	B967228009	Head hinge	2	
7-2	B967190001	Rubber cushion	2	
7-3	BXF9148009	Head cushion< for left side>	2	
7-4	BXF9147009	Head cushion< for right side>	2	
8	W050202013	Oiler assy	4	
9	W050202009	Oil tank assy	1	
10	W060302076	Head cover	1	
11	006F00030	Cotton stand assy 2DR	1	
12	BXF9789909	Oil pan assy	1	
12-1	BXF9788809	Oil pan	1	
12-2	BXF9787009	Knee lifter shaft L	1	
12-3	BXF9786009	Knee lifter shaft R	1	
12-4	BXF9785009	Knee lifter limit support	1	
12-5	BXF9784009	Knee lifter R	1	
12-6	BX85766009	Bolt M6	1	
12-7	BX85635009	Set screw M6x19	2	
12-8	B089040704	Nut M6	2	
12-9	B7F7502009	Twist spring	2	
12-10	B964817009	Retaining ring E10	1	
12-11	BXF9783009	Knee lifter connecting rod	1	
12-12	217100037	Shoulder screw M5	1	
12-13	B961532080	Bush	2	
12-14	S150503004	Nut M5	4	
14	BX75289089	Knee lifter assy	1	
14-1	B964071089	Knee lifter bracket	1	
14-2	B900647009	Bolt square SM7.94	1	
14-3	BX75280089	Bolt SM5.95x20	1	
14-4	230100022	Knee lifter bar	1	
14-5	022920009	Knee lifter plate	1	
14-6	B996143009	Knee lifter plate stopper	1	
14-7	B990023009	Bolt SM5.95-28x8	1	
14-8	W210105006	Knee lifter plate cover	1	

Machine specifications

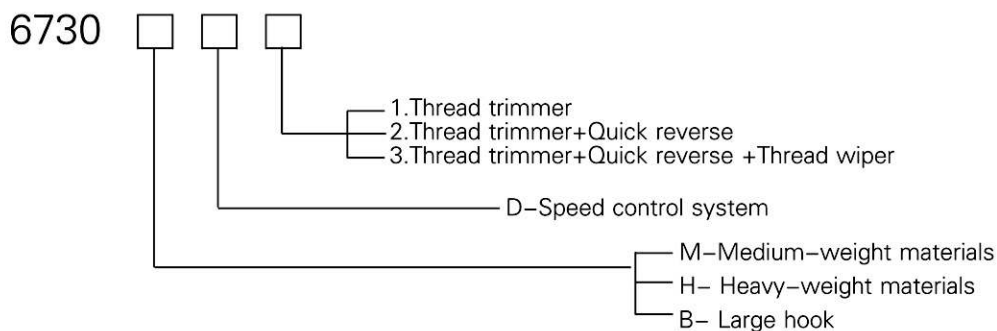

Machine's main technical data

		GC6730MD3	GC6760HD3	GC6760BD3
Max.sewing speed		5000rpm	4500rpm	3500rpm
Max. stitch length		5mm		7mm
Presser foot height	Lifting lever	6mm		
	knee lifter	13mm		
Feed dog height		0.8mm	1.2mm	
Needle		DBx1 #11-#16	DPx5 #18-#22	

When GC6730M/HD3 sewing at speeds of 4000 rpm or higher, set the stitch length to 4.2 mm or less.

When GC6730BD3 sewing at speeds of 3000 rpm or higher, set the stitch length to 5 mm or less.

● Besides adjusting stitch, please laypeople don't debug or maintain.

● Parts are subject to changes in design without prior notice.

XI'AN TYPICAL INDUSTRIES CO.,LTD.

Add: No.1 Taibai South Road,
Xi'an, P.R.China-710068
Tel :+86-29-88279091 88279150
Fax :+86-29-88249715 88245215
E-mail: typical@chinatypical.com
Http: www.chinatypical.com
Http: www.globalsources.com